

COMUNE DI PRATO

ASSESSORE AI LAVORI PUBBLICI	ENRICO GIARDI
Dirigente AREA OPERE PUBBLICHE E AMBIENTE	Ing. LORENZO FRASCONI
Dirigente SERVIZIO EDILIZIA PUBBLICA	Ing. PAOLO BARTALINI
CODICE FISCALE	84006890481
OGGETTO	REALIZZAZIONE DI TRE SEZIONI DI SCUOLA MATERNA A MEZZANA
UBICAZIONE	VIA VIOTTOLO DI MEZZANA
FASE	PROGETTO ESECUTIVO
ELABORATO	S_B FASCICOLO DI CALCOLO DELLE STRUTTURE
PROGETTISTA OPERE ARCHITETTONICHE	Ing. Paolo Bartalini
COLLABORATORI	Geom. Ivo Frosini - Geom. Antonio Silvestri
PROGETTISTA OPERE STRUTTURALI	Ing. Alessandro Becherucci
PROGETTISTA IMPIANTI MECCANICI	Ing. Leonardo Cecchi
PROGETTISTA IMPIANTI ELETTRICI	Ing. Vittorio Bardazzi
DATA	DICEMBRE 2006

INDICE

1 - Modellazione della struttura	pag. 3
2 - Verifica delle strutture allo SLD	pag. 22
3 - Verifica degli elementi in legno lamellare	pag. 23
4 - Verifica dei pilastri	pag. 33
5 - Verifica delle fondazioni	pag. 40
6 - Verifica del portale metallico	pag. 66

1 - Modellazione della struttura

La struttura in esame è costituita da pilastri in calcestruzzo armato, con solaio di copertura in legno lamellare con solo funzione di ripartizione del carico fra gli elementi verticali. Il metodo di calcolo utilizzato è di tipo elastico lineare con modellazione della struttura agli elementi finiti. Gli elementi utilizzati sono di tipo monodimensionale per la modellazione delle travi, mentre non è stata considerata a favore di sicurezza la rigidità del tavolato strutturale, affidando il comportamento a diaframma rigido nel piano del solaio solo alla presenza dei controventi metallici. I materiali sono stati considerati elastici lineari, ipotizzando per gli elementi in c.a. una rigidità pari a quella della sezione non parzializzata, trascurando il contributo dell'armatura metallica e riducendo il valore del modulo elastico per tener conto della fessurazione.

I carichi sono stati assegnati alle travi al loro valore caratteristico, in fase di verifica le sollecitazioni risultanti dall'analisi sono state combinate nelle modalità elencate nell'allegata relazione tecnica.

Le fondazioni a travi rovesce sono stati modellati su suolo elastico alla Winkler con costante di sottofondo stimata in 3 kg/cm^3 .

L'analisi sismica effettuata è del tipo dinamica modale con spettro di risposta. Si documentano nelle pagine seguenti i dati di input ed output sia nel formato grafico che numerico.

Modello globale

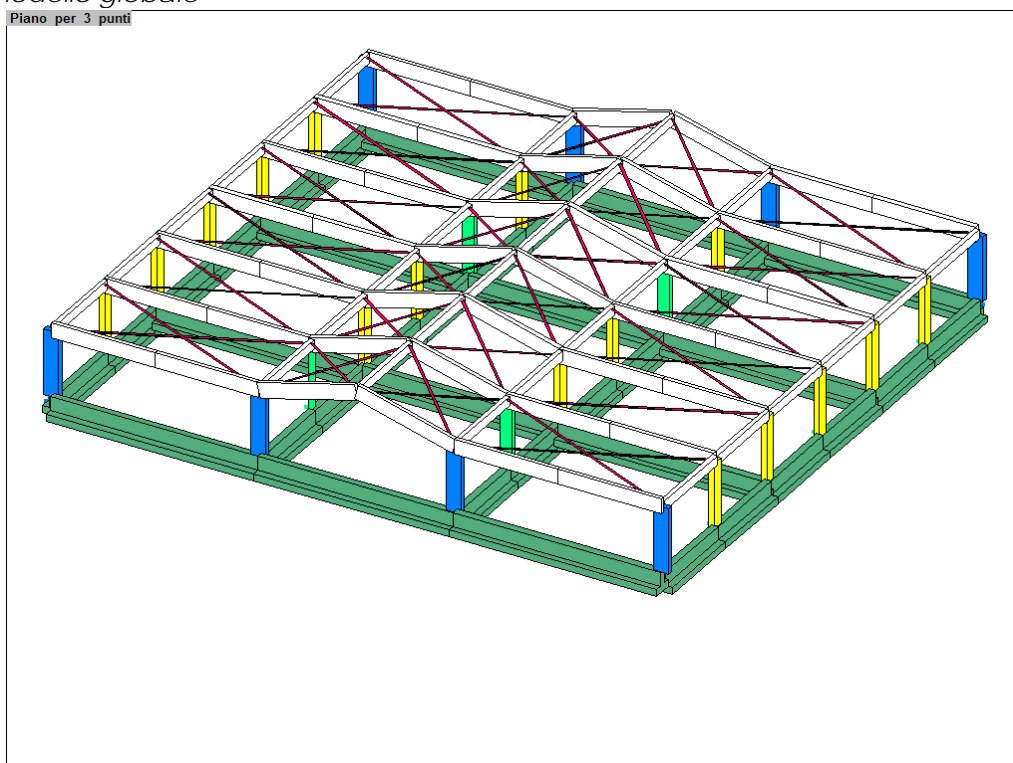

Spostamenti orizzontali sotto sisma x

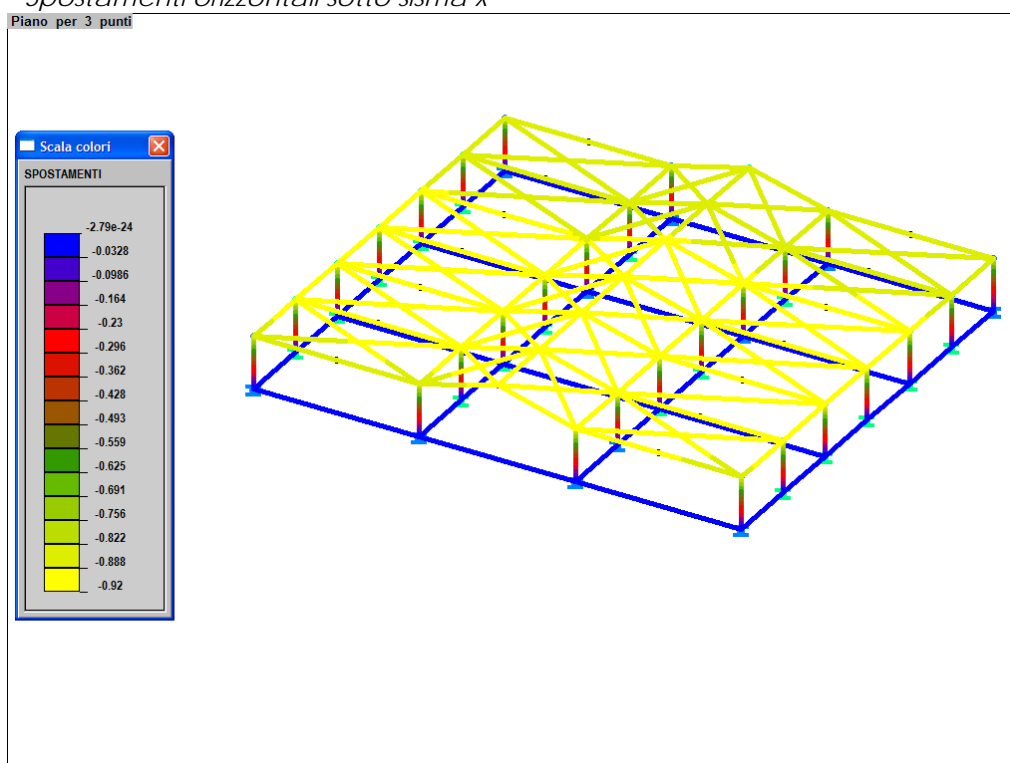

Spostamenti orizzontali sotto sisma y

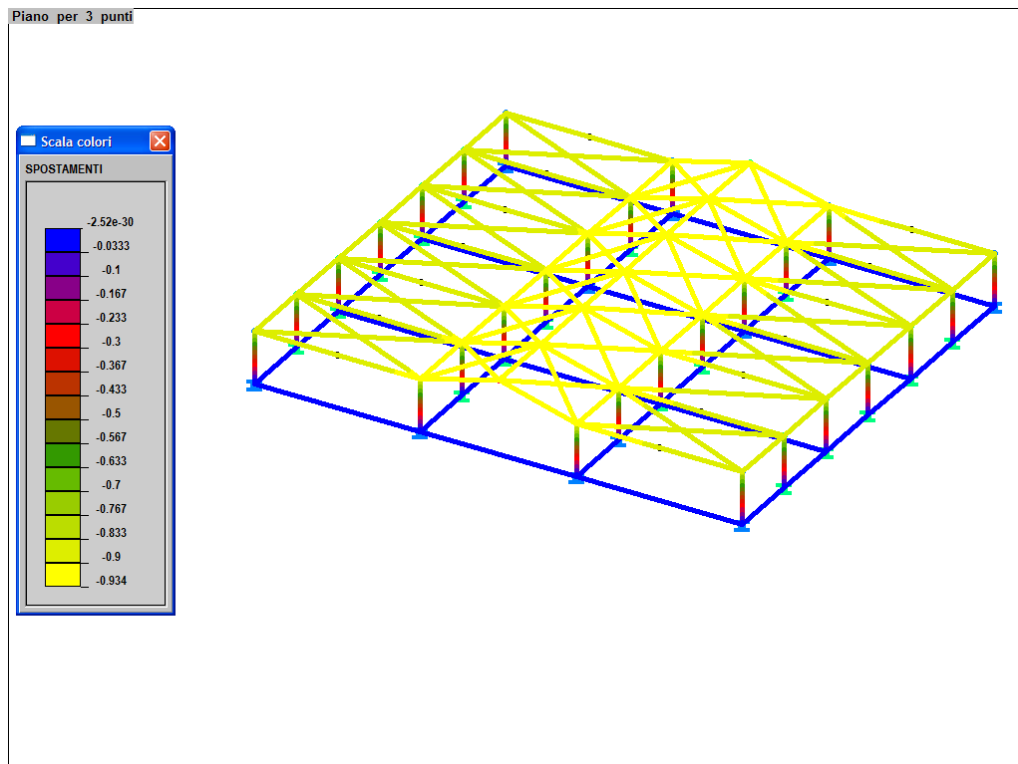

Prima forma modale

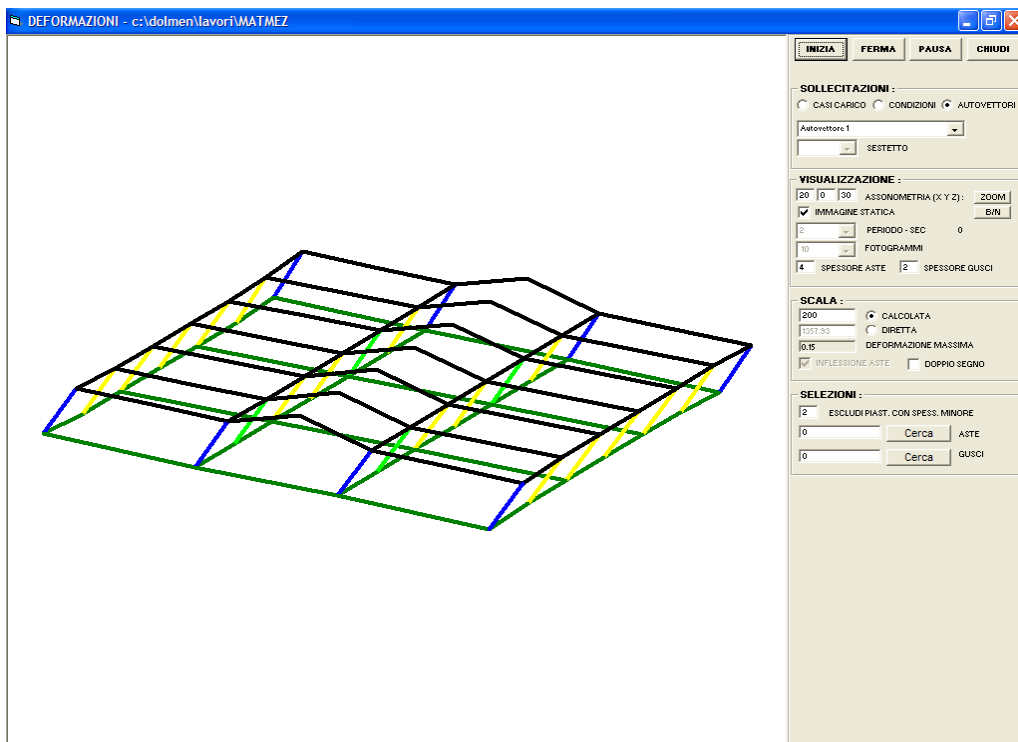

Seconda forma modale

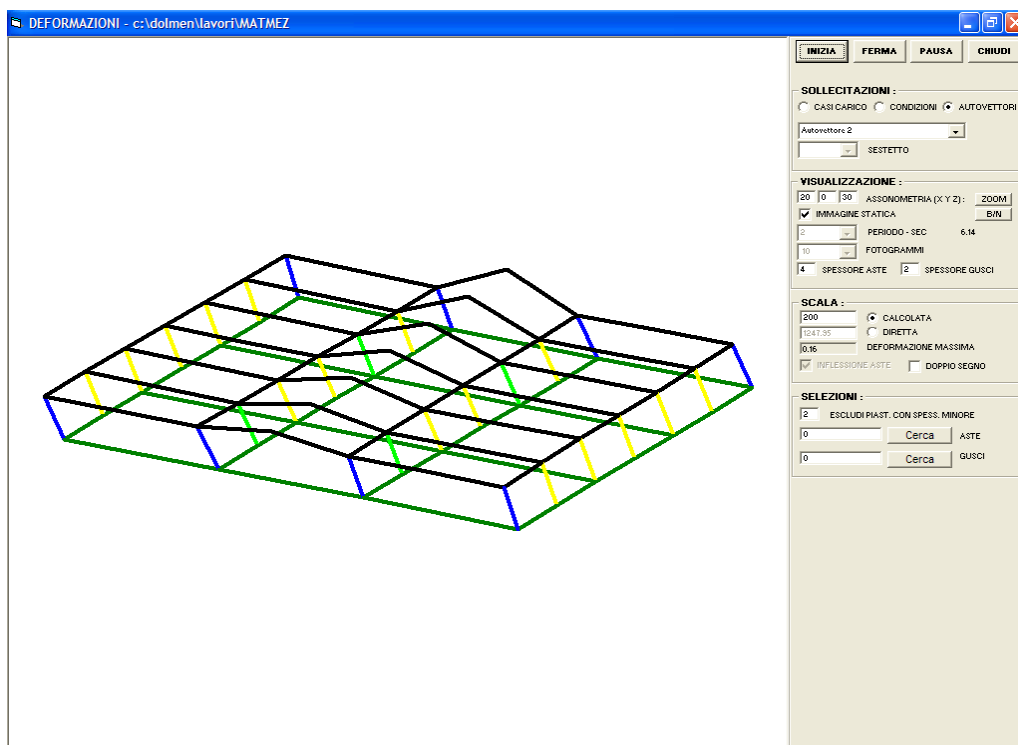

Momenti flettenti per carichi verticali(SLU)

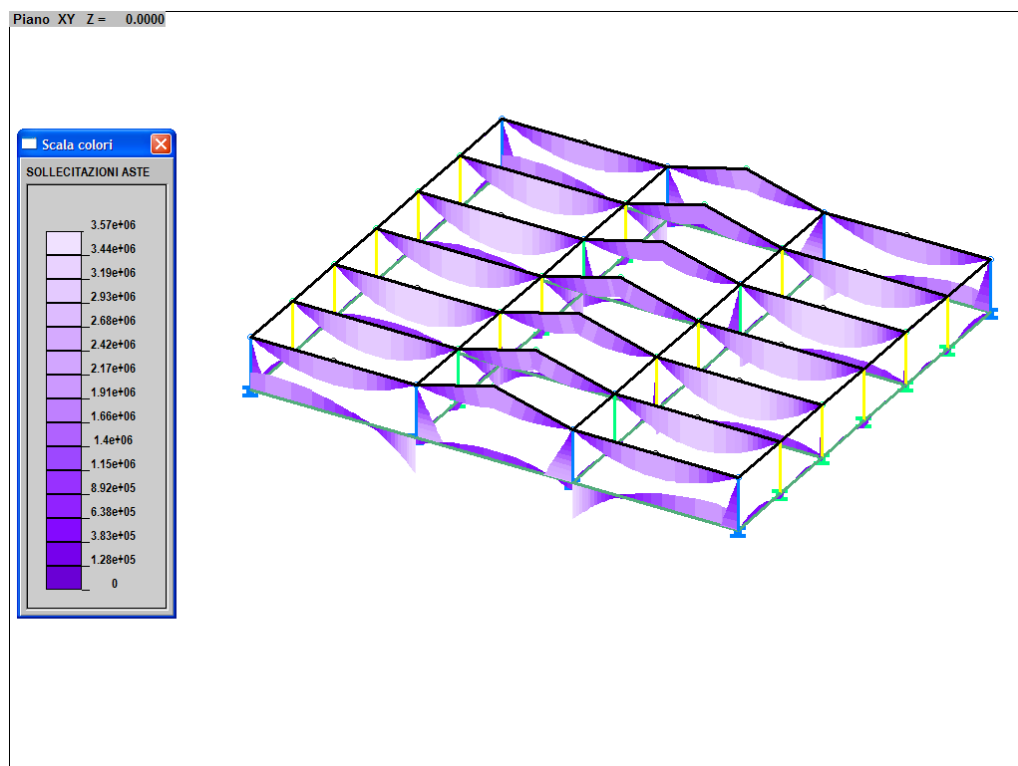

Momenti flettenti per carichi sismici (comb. Sx)

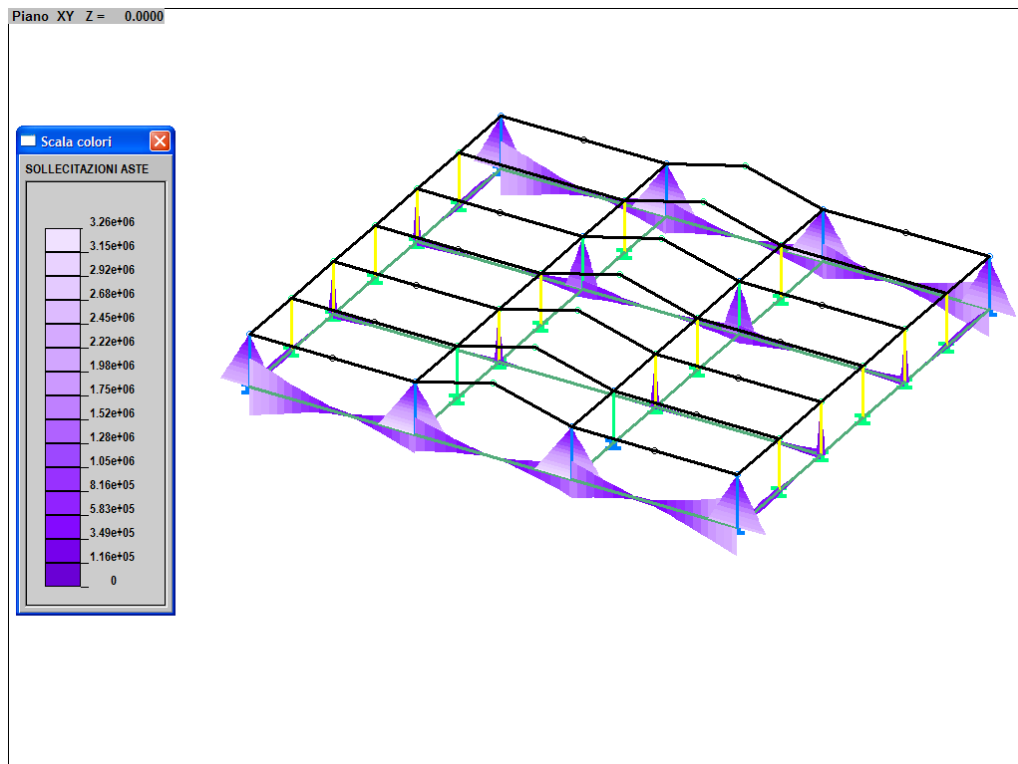

Momenti flettenti per carichi sismici (comb. Sy)

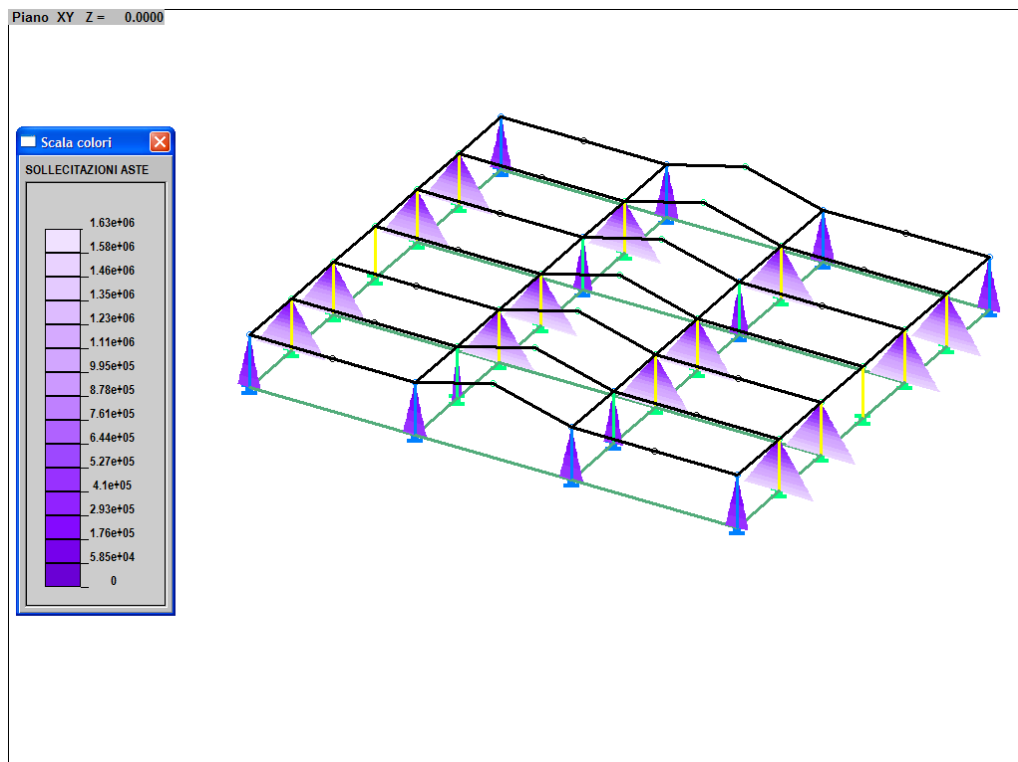

DATI NUMERICI

DATI STRUTTURA:

*** DATI STRUTTURA

NODI--	Coord. X	Coord. Y	Coord. Z	num. =
Nome				
1	0.0000	0.0000	0.0000	
2	0.0000	394.9996	0.0000	
3	0.0000	789.9992	0.0000	
4	0.0000	1184.9988	0.0000	
5	0.0000	1579.9983	0.0000	
6	0.0000	1974.9979	0.0000	
7	0.0000	2369.9975	0.0000	
8	0.0000	0.0000	285.0000	
9	0.0000	394.9996	285.0000	
10	0.0000	789.9992	285.0000	
11	0.0000	1184.9988	285.0000	
12	0.0000	1579.9983	285.0000	
13	0.0000	1974.9979	285.0000	
14	0.0000	2369.9975	285.0000	
15	450.0000	0.0000	285.0000	
16	450.0000	394.9996	285.0000	
17	450.0000	789.9992	285.0000	
18	450.0000	1184.9988	285.0000	
19	450.0000	1579.9983	285.0000	
20	450.0000	1974.9979	285.0000	
21	450.0000	2369.9975	285.0000	
22	900.0012	0.0000	0.0000	
23	900.0012	394.9996	0.0000	
24	900.0012	789.9992	0.0000	
25	900.0012	1184.9988	0.0000	
26	900.0012	1579.9983	0.0000	
27	900.0012	1974.9979	0.0000	
28	900.0012	2369.9975	0.0000	
29	900.0012	0.0000	285.0000	
30	900.0012	394.9996	285.0000	
31	900.0012	789.9992	285.0000	
32	900.0012	1184.9988	285.0000	
33	900.0012	1579.9983	285.0000	
34	900.0012	1974.9979	285.0000	
35	900.0012	2369.9975	285.0000	
36	1325.0012	0.0000	400.0000	
37	1325.0012	394.9996	400.0000	
38	1325.0012	789.9992	400.0000	
39	1325.0012	1184.9988	400.0000	
40	1325.0012	1579.9984	400.0000	
41	1325.0012	1974.9979	400.0000	
42	1325.0012	2369.9975	400.0000	
43	1749.8869	0.0000	0.0000	
44	1749.8869	394.9996	0.0000	
45	1749.8869	789.9992	0.0000	
46	1749.8869	1184.9988	0.0000	
47	1749.8869	1579.9984	0.0000	
48	1749.8869	1974.9979	0.0000	
49	1749.8869	2369.9975	0.0000	
50	1749.8869	0.0000	285.0000	
51	1749.8869	394.9996	285.0000	
52	1749.8869	789.9992	285.0000	
53	1749.8869	1184.9988	285.0000	
54	1749.8869	1579.9984	285.0000	
55	1749.8869	1974.9979	285.0000	
56	1749.8869	2369.9975	285.0000	
57	2199.8869	0.0000	285.0000	

58	2199.8869	394.9996	285.0000
59	2199.8869	789.9992	285.0000
60	2199.8869	1184.9988	285.0000
61	2199.8869	1579.9984	285.0000
62	2199.8869	1974.9979	285.0000
63	2199.8869	2369.9975	285.0000
64	2650.0012	0.0000	0.0000
65	2650.0012	394.9996	0.0000
66	2650.0012	789.9992	0.0000
67	2650.0012	1184.9988	0.0000
68	2650.0012	1579.9984	0.0000
69	2650.0012	1974.9979	0.0000
70	2650.0012	2369.9975	0.0000
71	2650.0012	0.0000	285.0000
72	2650.0012	394.9996	285.0000
73	2650.0012	789.9992	285.0000
74	2650.0012	1184.9988	285.0000
75	2650.0012	1579.9984	285.0000
76	2650.0012	1974.9979	285.0000
77	2650.0012	2369.9975	285.0000

ASTE--	-----	-----	-----	-----	-----	num. =	183
Nome	Proprieta`	Nodo iniz.	Nodo fin.	Rilasci in.	Rilasci fin.		Orient.
25	2	8	9	RyRz	RxRyRz		0.0
26	2	9	10	RyRz	RxRyRz		0.0
27	2	10	11	RyRz	RxRyRz		0.0
28	2	11	12	RyRz	RxRyRz		0.0
29	2	12	13	RyRz	RxRyRz		0.0
30	2	13	14	RyRz	RxRyRz		0.0
31	2	71	72	RyRz	RxRyRz		0.0
32	2	72	73	RyRz	RxRyRz		0.0
33	2	73	74	RyRz	RxRyRz		0.0
34	2	74	75	RyRz	RxRyRz		0.0
35	2	75	76	RyRz	RxRyRz		0.0
36	2	76	77	RyRz	RxRyRz		0.0
37	2	29	30	RyRz	RxRyRz		0.0
38	2	30	31	RyRz	RxRyRz		0.0
39	2	31	32	RyRz	RxRyRz		0.0
40	2	32	33	RyRz	RxRyRz		0.0
41	2	33	34	RyRz	RxRyRz		0.0
42	2	34	35	RyRz	RxRyRz		0.0
43	2	50	51	RyRz	RxRyRz		0.0
44	2	51	52	RyRz	RxRyRz		0.0
45	2	52	53	RyRz	RxRyRz		0.0
46	2	53	54	RyRz	RxRyRz		0.0
47	2	54	55	RyRz	RxRyRz		0.0
48	2	55	56	RyRz	RxRyRz		0.0
67	3	6	13				0.0
68	3	5	12				0.0
69	3	4	11	RyRz	RxRyRz		0.0
70	3	3	10				0.0
71	3	2	9				0.0
72	3	65	72				0.0
73	3	66	73				0.0
74	3	67	74	RyRz	RxRyRz		0.0
75	3	68	75				0.0
76	3	69	76				0.0
77	6	7	14				0.0
78	6	28	35				0.0
79	6	49	56				0.0
80	6	70	77				0.0
81	6	64	71				0.0
82	6	43	50				0.0
83	6	22	29				0.0
84	6	1	8				0.0
85	3	27	34				0.0

86	3	48	55			0.0
87	3	25	32			0.0
88	3	46	53			0.0
89	3	45	52			0.0
90	3	24	31			0.0
91	4	26	33			0.0
92	4	47	54			0.0
93	4	44	51			0.0
95	1	29	36	RxRyRz		0.0
96	1	36	50		RxRyRz	0.0
111	1	30	37	RxRyRz		0.0
112	1	37	51		RxRyRz	0.0
113	1	31	38	RxRyRz		0.0
114	1	38	52		RxRyRz	0.0
115	1	32	39	RxRyRz		0.0
116	1	39	53		RxRyRz	0.0
117	1	33	40	RxRyRz		0.0
118	1	40	54		RxRyRz	0.0
119	1	34	41	RxRyRz		0.0
120	1	41	55		RxRyRz	0.0
121	1	35	42	RxRyRz		0.0
122	1	42	56		RxRyRz	0.0
123	5	1	22	Rx		180.0
124	5	22	43	Rx		180.0
125	5	43	64	Rx		180.0
126	5	64	65	Rx		180.0
127	5	65	66	Rx		180.0
128	5	66	67	Rx		180.0
129	5	67	68	Rx		180.0
130	5	68	69	Rx		180.0
131	5	69	70	Rx		180.0
132	5	70	49	Rx		180.0
133	5	49	28	Rx		180.0
134	5	28	7	Rx		180.0
135	5	7	6	Rx		180.0
136	5	6	5	Rx		180.0
137	5	5	4	Rx		180.0
138	5	4	3	Rx		180.0
139	5	3	2	Rx		180.0
140	5	2	1	Rx		180.0
141	5	22	23	Rx		180.0
142	5	23	24	Rx		180.0
143	5	24	25	Rx		180.0
144	5	25	26	Rx		180.0
145	5	26	27	Rx		180.0
146	5	27	28	Rx		180.0
147	5	49	48	Rx		180.0
148	5	48	47	Rx		180.0
149	5	46	45	Rx		180.0
150	5	47	46	Rx		180.0
151	5	45	44	Rx		180.0
152	5	44	43	Rx		180.0
153	5	68	47	Rx		180.0
154	5	47	26	Rx		180.0
155	5	26	5	Rx		180.0
156	5	66	45	Rx		180.0
157	5	45	24	Rx		180.0
158	5	24	3	Rx		180.0
159	1	14	21	RxRyRz		0.0
160	1	21	35		RxRyRz	0.0
161	1	13	20	RxRyRz		0.0
162	1	20	34		RxRyRz	0.0
163	1	12	19	RxRyRz		0.0
164	1	19	33		RxRyRz	0.0
165	1	11	18	RxRyRz		0.0
166	1	18	32		RxRyRz	0.0

167	1	10	17	RxRyRz		0.0
168	1	17	31		RxRyRz	0.0
169	1	9	16	RxRyRz		0.0
170	1	16	30		RxRyRz	0.0
171	1	8	15	RxRyRz		0.0
172	1	15	29		RxRyRz	0.0
173	1	56	63	RxRyRz		0.0
174	1	63	77		RxRyRz	0.0
175	1	55	62	RxRyRz		0.0
176	1	62	76		RxRyRz	0.0
177	1	54	61	RxRyRz		0.0
178	1	61	75		RxRyRz	0.0
179	1	53	60	RxRyRz		0.0
180	1	60	74		RxRyRz	0.0
181	1	52	59	RxRyRz		0.0
182	1	59	73		RxRyRz	0.0
183	1	51	58	RxRyRz		0.0
184	1	58	72		RxRyRz	0.0
185	1	50	57	RxRyRz		0.0
186	1	57	71		RxRyRz	0.0
187	4	23	30			0.0
212	7	8	30	FUNE		0.0
213	7	30	10	FUNE		0.0
214	7	10	32	FUNE		0.0
215	7	32	12	FUNE		0.0
216	7	12	34	FUNE		0.0
217	7	34	14	FUNE		0.0
218	7	35	13	FUNE		0.0
219	7	13	33	FUNE		0.0
220	7	33	11	FUNE		0.0
221	7	11	31	FUNE		0.0
222	7	9	31	FUNE		0.0
223	7	9	29	FUNE		0.0
224	7	50	72	FUNE		0.0
225	7	71	51	FUNE		0.0
226	7	51	73	FUNE		0.0
227	7	73	53	FUNE		0.0
228	7	52	74	FUNE		0.0
229	7	74	54	FUNE		0.0
230	7	53	75	FUNE		0.0
231	7	75	55	FUNE		0.0
232	7	54	76	FUNE		0.0
233	7	56	76	FUNE		0.0
234	7	77	55	FUNE		0.0
235	7	50	37	FUNE		0.0
236	7	37	52	FUNE		0.0
237	7	52	39	FUNE		0.0
238	7	39	54	FUNE		0.0
239	7	54	41	FUNE		0.0
240	7	41	56	FUNE		0.0
241	7	42	55	FUNE		0.0
242	7	55	40	FUNE		0.0
243	7	40	53	FUNE		0.0
244	7	53	38	FUNE		0.0
245	7	38	51	FUNE		0.0
246	7	51	36	FUNE		0.0
247	7	36	30	FUNE		0.0
248	7	30	38	FUNE		0.0
249	7	38	32	FUNE		0.0
250	7	32	40	FUNE		0.0
251	7	40	34	FUNE		0.0
252	7	34	42	FUNE		0.0
253	7	35	41	FUNE		0.0
254	7	41	33	FUNE		0.0
255	7	33	39	FUNE		0.0
256	7	39	31	FUNE		0.0

257	7	31	37	FUNE			0.0
258	7	37	29	FUNE			0.0
259	2	36	37	RyRz	RxRyRz		0.0
260	2	37	38	RyRz	RxRyRz		0.0
261	2	38	39	RyRz	RxRyRz		0.0
263	2	40	41	RyRz	RxRyRz		0.0
264	2	41	42	RyRz	RxRyRz		0.0
265	2	39	40	RyRz	RxRyRz		0.0

GUSCI RETTANGOLARI							num. =	36
Nome	Proprieta`	Nodo 1	Nodo 2	Nodo 3	Nodo 4			
13	1	13	20	21	14			
14	1	20	34	35	21			
15	1	12	19	20	13			
16	1	19	33	34	20			
17	1	11	18	19	12			
18	1	18	32	33	19			
19	1	10	17	18	11			
20	1	17	31	32	18			
21	1	9	16	17	10			
22	1	16	30	31	17			
23	1	8	15	16	9			
24	1	15	29	30	16			
25	1	55	62	63	56			
26	1	62	76	77	63			
27	1	54	61	62	55			
28	1	61	75	76	62			
29	1	53	60	61	54			
30	1	60	74	75	61			
31	1	52	59	60	53			
32	1	59	73	74	60			
33	1	51	58	59	52			
34	1	58	72	73	59			
35	1	50	57	58	51			
36	1	57	71	72	58			
37	1	29	36	37	30			
38	1	30	37	38	31			
39	1	31	38	39	32			
40	1	32	39	40	33			
41	1	33	40	41	34			
42	1	34	41	42	35			
43	1	36	50	51	37			
44	1	37	51	52	38			
45	1	38	52	53	39			
46	1	39	53	54	40			
47	1	40	54	55	41			
48	1	41	55	56	42			

PROPRIETA` ASTE							num. =	7
Nome	Materiale	Base	Altezza	Area	Area tag. Y	Area tag. Z		
		Kw vertic.	Kw orizz.	J tors.	J fless. Y	J fless. Z		
1	3	20.0000	65.0000	1.30000E+03	1.08333E+03	1.08333E+03		
		0.0000	0.0000	1.39757E+05	4.33333E+04	4.57708E+05		
2	3	20.0000	40.0000	8.00000E+02	6.66667E+02	6.66667E+02		
		0.0000	0.0000	7.32410E+04	2.66667E+04	1.06667E+05		
3	1	50.0000	25.0000	1.25000E+03	1.04167E+03	1.04167E+03		
		0.0000	0.0000	1.78811E+05	2.60417E+05	6.51042E+04		
4	1	25.0000	50.0000	1.25000E+03	1.04167E+03	1.04167E+03		
		0.0000	0.0000	1.78811E+05	6.51042E+04	2.60417E+05		
5	1	90.0000	90.0000	4.50000E+03	2.70000E+03	2.70000E+03		
		3.0000	0.0000	1.14533E+06	1.95750E+06	2.92950E+06		
6	1	25.0000	65.0000	1.62500E+03	1.35417E+03	1.35417E+03		
		0.0000	0.0000	2.56658E+05	8.46354E+04	5.72135E+05		
7	2	10.0000	0.6000	6.00000E+00	5.00000E+00	5.00000E+00		
		0.0000	0.0000	6.92780E-01	5.00000E+01	1.80000E-01		

PROPRIETA` GUSCI					num. =
Nome	Materiale	Sp.membr.	Sp. piastra	Kw	
1	3	3.0000	1.0000	0.0000	1

MATERIALI						num. =
Nome	Mod. elast.	Coeff. nu	Mod. tang.	Peso spec.	Dil. te.	
1	2.00000E+05	1.50000E-01	1.30000E+05	2.50000E-03	1.00000E-05	3
2	2.10000E+06	3.00000E-01	8.50000E+05	7.85000E-03	1.00000E-05	
3	1.37000E+05	2.00000E-01	8.50000E+03	4.50000E-03	1.00000E-05	

VINCOLI							num. =
Nodo	Rigid. X	Rigid. Y	Rigid. Z	Rigid. RX	Rigid. RY	Rigid. RZ	
6	bloccato	bloccato	libero	libero	libero	libero	
5	bloccato	bloccato	libero	libero	libero	libero	
4	bloccato	bloccato	libero	libero	libero	libero	
3	bloccato	bloccato	libero	libero	libero	libero	
2	bloccato	bloccato	libero	libero	libero	libero	
65	bloccato	bloccato	libero	libero	libero	libero	
66	bloccato	bloccato	libero	libero	libero	libero	
67	bloccato	bloccato	libero	libero	libero	libero	
68	bloccato	bloccato	libero	libero	libero	libero	
69	bloccato	bloccato	libero	libero	libero	libero	
7	bloccato	bloccato	libero	libero	libero	libero	
28	bloccato	bloccato	libero	libero	libero	libero	
49	bloccato	bloccato	libero	libero	libero	libero	
70	bloccato	bloccato	libero	libero	libero	libero	
64	bloccato	bloccato	libero	libero	libero	libero	
43	bloccato	bloccato	libero	libero	libero	libero	
22	bloccato	bloccato	libero	libero	libero	libero	
1	bloccato	bloccato	libero	libero	libero	libero	
27	bloccato	bloccato	libero	libero	libero	libero	
48	bloccato	bloccato	libero	libero	libero	libero	
25	bloccato	bloccato	libero	libero	libero	libero	
46	bloccato	bloccato	libero	libero	libero	libero	
45	bloccato	bloccato	libero	libero	libero	libero	
24	bloccato	bloccato	libero	libero	libero	libero	
26	bloccato	bloccato	libero	libero	libero	libero	
47	bloccato	bloccato	libero	libero	libero	libero	
44	bloccato	bloccato	libero	libero	libero	libero	
23	bloccato	bloccato	libero	libero	libero	libero	

CARICHI NODI				num. =
Nome	Nodo	Direzione	Intensita`	
1 D001	8	X	1.4968E+03	381
2 D001	9	X	1.9584E+03	
3 D001	10	X	1.9418E+03	
4 D001	11	X	1.6923E+03	
5 D001	12	X	1.8908E+03	
6 D001	13	X	1.8610E+03	
7 D001	14	X	1.3884E+03	
8 D001	15	X	2.6001E+03	
9 D001	16	X	2.3523E+03	
10 D001	17	X	2.7065E+03	
11 D001	18	X	2.3339E+03	
12 D001	19	X	2.6337E+03	
13 D001	20	X	2.2350E+03	
14 D001	21	X	2.4118E+03	
15 D001	29	X	1.6452E+03	
16 D001	30	X	1.8698E+03	
17 D001	31	X	1.9789E+03	
18 D001	32	X	1.8532E+03	
19 D001	33	X	1.9217E+03	
20 D001	34	X	1.7764E+03	
21 D001	35	X	1.5259E+03	
22 D001	36	X	1.5618E+03	
23 D001	37	X	2.0092E+03	

24	D001	38	X	2.0081E+03
25	D001	39	X	1.9902E+03
26	D001	40	X	1.9530E+03
27	D001	41	X	1.9090E+03
28	D001	42	X	1.4491E+03
29	D001	50	X	1.7829E+03
30	D001	51	X	2.1384E+03
31	D001	52	X	2.2490E+03
32	D001	53	X	2.1205E+03
33	D001	54	X	2.1844E+03
34	D001	55	X	2.0326E+03
35	D001	56	X	1.6549E+03
36	D001	57	X	2.6203E+03
37	D001	58	X	2.3715E+03
38	D001	59	X	2.7294E+03
39	D001	60	X	2.3541E+03
40	D001	61	X	2.6567E+03
41	D001	62	X	2.2544E+03
42	D001	63	X	2.4324E+03
43	D001	71	X	1.5084E+03
44	D001	72	X	1.9743E+03
45	D001	73	X	1.9582E+03
46	D001	74	X	1.7069E+03
47	D001	75	X	1.9072E+03
48	D001	76	X	1.8770E+03
49	D001	77	X	1.4004E+03
50	D001	8	Y	-5.0620E-02
51	D001	9	Y	-8.0440E-02
52	D001	10	Y	-1.0990E-01
53	D001	11	Y	-1.2669E-01
54	D001	12	Y	-1.7670E-01
55	D001	13	Y	-2.0489E-01
56	D001	14	Y	-1.7069E-01
57	D001	15	Y	-9.8930E-02
58	D001	16	Y	-9.1830E-02
59	D001	17	Y	-1.1473E-01
60	D001	18	Y	-1.1327E-01
61	D001	19	Y	-1.4378E-01
62	D001	20	Y	-1.3163E-01
63	D001	21	Y	-1.5060E-01
64	D001	29	Y	-3.5070E-02
65	D001	30	Y	-3.9440E-02
66	D001	31	Y	-4.1560E-02
67	D001	32	Y	-3.9870E-02
68	D001	33	Y	-4.2900E-02
69	D001	34	Y	-4.0240E-02
70	D001	35	Y	-3.5810E-02
71	D001	36	Y	6.4300E-03
72	D001	37	Y	7.9900E-03
73	D001	38	Y	7.5500E-03
74	D001	39	Y	7.0500E-03
75	D001	40	Y	6.5700E-03
76	D001	41	Y	6.1900E-03
77	D001	42	Y	4.6500E-03
78	D001	50	Y	5.0780E-02
79	D001	51	Y	6.0090E-02
80	D001	52	Y	6.2680E-02
81	D001	53	Y	5.9970E-02
82	D001	54	Y	6.3570E-02
83	D001	55	Y	5.9870E-02
84	D001	56	Y	5.0410E-02
85	D001	57	Y	1.1666E-01
86	D001	58	Y	1.0775E-01
87	D001	59	Y	1.3319E-01
88	D001	60	Y	1.2948E-01
89	D001	61	Y	1.6261E-01

90	D001	62	Y	1.4815E-01
91	D001	63	Y	1.6909E-01
92	D001	71	Y	5.9830E-02
93	D001	72	Y	9.2460E-02
94	D001	73	Y	1.2233E-01
95	D001	74	Y	1.3818E-01
96	D001	75	Y	1.9042E-01
97	D001	76	Y	2.1920E-01
98	D001	77	Y	1.8202E-01
99	D002	8	X	-3.5296E-01
100	D002	9	X	-2.8816E-01
101	D002	10	X	-1.3641E-01
102	D002	12	X	1.5311E-01
103	D002	13	X	3.0532E-01
104	D002	14	X	3.6208E-01
105	D002	15	X	-5.9900E-01
106	D002	16	X	-3.4459E-01
107	D002	17	X	-1.8910E-01
108	D002	19	X	2.1295E-01
109	D002	20	X	3.6659E-01
110	D002	21	X	6.1364E-01
111	D002	29	X	-3.6595E-01
112	D002	30	X	-2.7002E-01
113	D002	31	X	-1.3588E-01
114	D002	33	X	1.5406E-01
115	D002	34	X	2.8883E-01
116	D002	35	X	3.7424E-01
117	D002	36	X	-2.0460E-02
118	D002	37	X	-1.3710E-02
119	D002	39	X	9.9900E-03
120	D002	40	X	2.1710E-02
121	D002	41	X	3.3480E-02
122	D002	42	X	3.5640E-02
123	D002	50	X	3.4808E-01
124	D002	51	X	2.7754E-01
125	D002	52	X	1.4921E-01
126	D002	53	X	1.8040E-02
127	D002	54	X	-1.2534E-01
128	D002	55	X	-2.5706E-01
129	D002	56	X	-3.2243E-01
130	D002	57	X	5.3342E-01
131	D002	58	X	3.1279E-01
132	D002	59	X	1.8433E-01
133	D002	60	X	1.6690E-02
134	D002	61	X	-1.5420E-01
135	D002	62	X	-2.8839E-01
136	D002	63	X	-4.9725E-01
137	D002	71	X	3.1547E-01
138	D002	72	X	2.6170E-01
139	D002	73	X	1.3296E-01
140	D002	74	X	1.1060E-02
141	D002	75	X	-1.1091E-01
142	D002	76	X	-2.4022E-01
143	D002	77	X	-2.9534E-01
144	D002	8	Y	1.3913E+03
145	D002	9	Y	1.7828E+03
146	D002	10	Y	1.7678E+03
147	D002	11	Y	1.5516E+03
148	D002	12	Y	1.7675E+03
149	D002	13	Y	1.7828E+03
150	D002	14	Y	1.3917E+03
151	D002	15	Y	2.5310E+03
152	D002	16	Y	2.2660E+03
153	D002	17	Y	2.6026E+03
154	D002	18	Y	2.2621E+03
155	D002	19	Y	2.6005E+03

156	D002	20	Y	2.2647E+03
157	D002	21	Y	2.5287E+03
158	D002	29	Y	1.6676E+03
159	D002	30	Y	1.8734E+03
160	D002	31	Y	1.9781E+03
161	D002	32	Y	1.8665E+03
162	D002	33	Y	1.9810E+03
163	D002	34	Y	1.8668E+03
164	D002	35	Y	1.6618E+03
165	D002	36	Y	1.6295E+03
166	D002	37	Y	2.0878E+03
167	D002	38	Y	2.0873E+03
168	D002	39	Y	2.0847E+03
169	D002	40	Y	2.0824E+03
170	D002	41	Y	2.0857E+03
171	D002	42	Y	1.6282E+03
172	D002	50	Y	1.8058E+03
173	D002	51	Y	2.1399E+03
174	D002	52	Y	2.2444E+03
175	D002	53	Y	2.1319E+03
176	D002	54	Y	2.2477E+03
177	D002	55	Y	2.1323E+03
178	D002	56	Y	1.7995E+03
179	D002	57	Y	2.5645E+03
180	D002	58	Y	2.2960E+03
181	D002	59	Y	2.6369E+03
182	D002	60	Y	2.2919E+03
183	D002	61	Y	2.6348E+03
184	D002	62	Y	2.2946E+03
185	D002	63	Y	2.5620E+03
186	D002	71	Y	1.4192E+03
187	D002	72	Y	1.8185E+03
188	D002	73	Y	1.8033E+03
189	D002	74	Y	1.5827E+03
190	D002	75	Y	1.8028E+03
191	D002	76	Y	1.8182E+03
192	D002	77	Y	1.4193E+03
193	SX	14	X	1.7205E+03
194	SX	35	X	1.9882E+03
195	SX	56	X	2.1105E+03
196	SX	77	X	1.7208E+03
197	SX	13	X	2.1169E+03
198	SX	34	X	2.2015E+03
199	SX	55	X	2.4463E+03
200	SX	76	X	2.1171E+03
201	SX	12	X	2.1339E+03
202	SX	33	X	2.3411E+03
203	SX	54	X	2.5859E+03
204	SX	75	X	2.1342E+03
205	SX	11	X	1.8718E+03
206	SX	32	X	2.2015E+03
207	SX	53	X	2.4463E+03
208	SX	74	X	1.8721E+03
209	SX	10	X	2.1339E+03
210	SX	31	X	2.3411E+03
211	SX	52	X	2.5859E+03
212	SX	73	X	2.1342E+03
213	SX	8	X	1.7205E+03
214	SX	29	X	1.9882E+03
215	SX	50	X	2.1105E+03
216	SX	71	X	1.7208E+03
217	SX	9	X	2.1169E+03
218	SX	72	X	2.1171E+03
219	SX	30	X	2.2015E+03
220	SX	51	X	2.4463E+03
221	SX	21	X	2.0804E+03

222	SX	20	X	1.8662E+03
223	SX	19	X	2.1453E+03
224	SX	18	X	1.8662E+03
225	SX	17	X	2.1453E+03
226	SX	16	X	1.8662E+03
227	SX	15	X	2.0804E+03
228	SX	63	X	2.0807E+03
229	SX	62	X	1.8664E+03
230	SX	61	X	2.1456E+03
231	SX	60	X	1.8664E+03
232	SX	59	X	2.1456E+03
233	SX	58	X	1.8664E+03
234	SX	57	X	2.0807E+03
235	SX	36	X	1.7622E+03
236	SX	37	X	2.2595E+03
237	SX	38	X	2.2595E+03
238	SX	39	X	2.2595E+03
239	SX	40	X	2.2595E+03
240	SX	41	X	2.2595E+03
241	SX	42	X	1.7622E+03
242	SY	14	Y	1.7205E+03
243	SY	35	Y	1.9882E+03
244	SY	56	Y	2.1105E+03
245	SY	77	Y	1.7208E+03
246	SY	13	Y	2.1169E+03
247	SY	34	Y	2.2015E+03
248	SY	55	Y	2.4463E+03
249	SY	76	Y	2.1171E+03
250	SY	12	Y	2.1339E+03
251	SY	33	Y	2.3411E+03
252	SY	54	Y	2.5859E+03
253	SY	75	Y	2.1342E+03
254	SY	11	Y	1.8718E+03
255	SY	32	Y	2.2015E+03
256	SY	53	Y	2.4463E+03
257	SY	74	Y	1.8721E+03
258	SY	10	Y	2.1339E+03
259	SY	31	Y	2.3411E+03
260	SY	52	Y	2.5859E+03
261	SY	73	Y	2.1342E+03
262	SY	8	Y	1.7205E+03
263	SY	29	Y	1.9882E+03
264	SY	50	Y	2.1105E+03
265	SY	71	Y	1.7208E+03
266	SY	9	Y	2.1169E+03
267	SY	72	Y	2.1171E+03
268	SY	30	Y	2.2015E+03
269	SY	51	Y	2.4463E+03
270	SY	21	Y	2.0804E+03
271	SY	20	Y	1.8662E+03
272	SY	19	Y	2.1453E+03
273	SY	18	Y	1.8662E+03
274	SY	17	Y	2.1453E+03
275	SY	16	Y	1.8662E+03
276	SY	15	Y	2.0804E+03
277	SY	63	Y	2.0807E+03
278	SY	62	Y	1.8664E+03
279	SY	61	Y	2.1456E+03
280	SY	60	Y	1.8664E+03
281	SY	59	Y	2.1456E+03
282	SY	58	Y	1.8664E+03
283	SY	57	Y	2.0807E+03
284	SY	36	Y	1.7622E+03
285	SY	37	Y	2.2595E+03
286	SY	38	Y	2.2595E+03
287	SY	39	Y	2.2595E+03

288	SY	40	Y	2.2595E+03
289	SY	41	Y	2.2595E+03
290	SY	42	Y	1.7622E+03
291	MadX	14	X	4.0130E+02
292	MadX	35	X	4.6373E+02
293	MadX	56	X	4.9227E+02
294	MadX	77	X	4.0136E+02
295	MadX	13	X	3.2916E+02
296	MadX	34	X	3.4233E+02
297	MadX	55	X	3.8040E+02
298	MadX	76	X	3.2920E+02
299	MadX	12	X	1.6591E+02
300	MadX	33	X	1.8201E+02
301	MadX	54	X	2.0105E+02
302	MadX	75	X	1.6593E+02
303	MadX	11	X	-2.8710E-06
304	MadX	32	X	-1.0540E-06
305	MadX	53	X	1.2660E-06
306	MadX	74	X	2.9440E-06
307	MadX	10	X	-1.6591E+02
308	MadX	31	X	-1.8201E+02
309	MadX	52	X	-2.0105E+02
310	MadX	73	X	-1.6593E+02
311	MadX	8	X	-4.0130E+02
312	MadX	29	X	-4.6373E+02
313	MadX	50	X	-4.9227E+02
314	MadX	71	X	-4.0136E+02
315	MadX	9	X	-3.2916E+02
316	MadX	72	X	-3.2920E+02
317	MadX	30	X	-3.4233E+02
318	MadX	51	X	-3.8040E+02
319	MadX	21	X	4.8525E+02
320	MadX	20	X	2.9018E+02
321	MadX	19	X	1.6680E+02
322	MadX	18	X	-1.8780E-06
323	MadX	17	X	-1.6680E+02
324	MadX	16	X	-2.9018E+02
325	MadX	15	X	-4.8525E+02
326	MadX	63	X	4.8531E+02
327	MadX	62	X	2.9022E+02
328	MadX	61	X	1.6682E+02
329	MadX	60	X	1.9500E-06
330	MadX	59	X	-1.6682E+02
331	MadX	58	X	-2.9022E+02
332	MadX	57	X	-4.8531E+02
333	MadX	36	X	-4.3280E+02
334	MadX	37	X	-3.6996E+02
335	MadX	38	X	-1.8498E+02
336	MadX	39	X	1.3660E-06
337	MadX	40	X	1.8498E+02
338	MadX	41	X	3.6996E+02
339	MadX	42	X	4.3280E+02
340	MadY	14	Y	-3.5149E+02
341	MadY	35	Y	-1.3176E+02
342	MadY	56	Y	1.3522E+02
343	MadY	77	Y	3.4778E+02
344	MadY	13	Y	-4.3246E+02
345	MadY	34	Y	-1.4589E+02
346	MadY	55	Y	1.5673E+02
347	MadY	76	Y	4.2789E+02
348	MadY	12	Y	-4.3595E+02
349	MadY	33	Y	-1.5514E+02
350	MadY	54	Y	1.6568E+02
351	MadY	75	Y	4.3134E+02
352	MadY	11	Y	-3.8240E+02
353	MadY	32	Y	-1.4589E+02

354	MadY	53	Y	1.5673E+02
355	MadY	74	Y	3.7836E+02
356	MadY	10	Y	-4.3595E+02
357	MadY	31	Y	-1.5514E+02
358	MadY	52	Y	1.6568E+02
359	MadY	73	Y	4.3134E+02
360	MadY	8	Y	-3.5149E+02
361	MadY	29	Y	-1.3176E+02
362	MadY	50	Y	1.3522E+02
363	MadY	71	Y	3.4778E+02
364	MadY	9	Y	-4.3246E+02
365	MadY	72	Y	4.2789E+02
366	MadY	30	Y	-1.4589E+02
367	MadY	51	Y	1.5673E+02
368	MadY	21	Y	-2.8145E+02
369	MadY	20	Y	-2.5246E+02
370	MadY	19	Y	-2.9023E+02
371	MadY	18	Y	-2.5246E+02
372	MadY	17	Y	-2.9023E+02
373	MadY	16	Y	-2.5246E+02
374	MadY	15	Y	-2.8145E+02
375	MadY	63	Y	2.7690E+02
376	MadY	62	Y	2.4838E+02
377	MadY	61	Y	2.8554E+02
378	MadY	60	Y	2.4838E+02
379	MadY	59	Y	2.8554E+02
380	MadY	58	Y	2.4838E+02
381	MadY	57	Y	2.7690E+02

CARICHI DI SOLAIO-|-----|-----|-----|-----|num.= 10

Nome	Cos X	Cos Y	Cos Z	Cond.	Rifer.	Intens.	Quota
1	0.0000	1.0000	0.0000	1	glob	-1.8500E-02	0.0000
2	0.0000	1.0000	0.0000	2	glob	-2.0000E-02	0.0000
3	0.0000	1.0000	0.0000	1	glob	-1.8500E-02	0.0000
4	0.0000	1.0000	0.0000	2	glob	-2.0000E-02	0.0000
5	0.0000	1.0000	0.0000	1	glob	-1.8500E-02	0.0000
6	0.0000	1.0000	0.0000	2	glob	-2.0000E-02	0.0000
7	0.0000	-1.0000	0.0000	1	glob	-1.8500E-02	0.0000
8	0.0000	-1.0000	0.0000	2	glob	-2.0000E-02	0.0000
9	0.0000	1.0000	0.0000	3	glob	-5.0000E-03	0.0000
10	0.0000	1.0000	0.0000	3	glob	-5.0000E-03	0.0000

CARICHI ASTE-----|-----|-----|-----|num.= 296

Nome	Asta	Dir	Tip	RIF	Parametro 1	Parametro 2	Parametro 3	Parametro 4
382	159	Z	FD	glo	-2.5000E+00			
383	160	Z	FD	glo	-2.5000E+00			
384	25	Z	FD	glo	-2.5000E+00			
385	26	Z	FD	glo	-2.5000E+00			
386	29	Z	FD	glo	-2.5000E+00			
387	30	Z	FD	glo	-2.5000E+00			
388	171	Z	FD	glo	-2.5000E+00			
389	172	Z	FD	glo	-2.5000E+00			
390	45	Z	FD	glo	-2.5000E+00			
391	46	Z	FD	glo	-2.5000E+00			
392	47	Z	FD	glo	-2.5000E+00			
393	48	Z	FD	glo	-2.5000E+00			
394	43	Z	FD	glo	-2.5000E+00			
395	44	Z	FD	glo	-2.5000E+00			
396	31	Z	FD	glo	-2.5000E+00			
397	32	Z	FD	glo	-2.5000E+00			
398	35	Z	FD	glo	-2.5000E+00			
399	36	Z	FD	glo	-2.5000E+00			
400	173	Z	FD	glo	-2.5000E+00			
401	174	Z	FD	glo	-2.5000E+00			
402	185	Z	FD	glo	-2.5000E+00			
403	186	Z	FD	glo	-2.5000E+00			

404		181	Z	FD glo	-2.5000E+00	
405		182	Z	FD glo	-2.5000E+00	
406		167	Z	FD glo	-2.5000E+00	
407		168	Z	FD glo	-2.5000E+00	
408		178	Z	FD glo	-2.5000E+00	
409		177	Z	FD glo	-2.5000E+00	
410		164	Z	FD glo	-2.5000E+00	
411		163	Z	FD glo	-2.5000E+00	
412	CS01	159	Z	FT glo	-3.6538E+00	-3.6538E+00
413	CS01	160	Z	FT glo	-3.6538E+00	-3.6538E+00
414	CS01	161	Z	FT glo	-7.3075E+00	-7.3075E+00
415	CS01	162	Z	FT glo	-7.3075E+00	-7.3075E+00
416	CS01	163	Z	FT glo	-7.3075E+00	-7.3075E+00
417	CS01	164	Z	FT glo	-7.3075E+00	-7.3075E+00
418	CS01	165	Z	FT glo	-7.3075E+00	-7.3075E+00
419	CS01	166	Z	FT glo	-7.3075E+00	-7.3075E+00
420	CS01	167	Z	FT glo	-7.3075E+00	-7.3075E+00
421	CS01	168	Z	FT glo	-7.3075E+00	-7.3075E+00
422	CS01	169	Z	FT glo	-7.3075E+00	-7.3075E+00
423	CS01	170	Z	FT glo	-7.3075E+00	-7.3075E+00
424	CS01	171	Z	FT glo	-3.6538E+00	-3.6538E+00
425	CS01	172	Z	FT glo	-3.6538E+00	-3.6538E+00
426	CS03	173	Z	FT glo	-3.6538E+00	-3.6538E+00
427	CS03	174	Z	FT glo	-3.6538E+00	-3.6538E+00
428	CS03	175	Z	FT glo	-7.3075E+00	-7.3075E+00
429	CS03	176	Z	FT glo	-7.3075E+00	-7.3075E+00
430	CS03	177	Z	FT glo	-7.3075E+00	-7.3075E+00
431	CS03	178	Z	FT glo	-7.3075E+00	-7.3075E+00
432	CS03	179	Z	FT glo	-7.3075E+00	-7.3075E+00
433	CS03	180	Z	FT glo	-7.3075E+00	-7.3075E+00
434	CS03	181	Z	FT glo	-7.3075E+00	-7.3075E+00
435	CS03	182	Z	FT glo	-7.3075E+00	-7.3075E+00
436	CS03	183	Z	FT glo	-7.3075E+00	-7.3075E+00
437	CS03	184	Z	FT glo	-7.3075E+00	-7.3075E+00
438	CS03	185	Z	FT glo	-3.6538E+00	-3.6538E+00
439	CS03	186	Z	FT glo	-3.6538E+00	-3.6538E+00
440	CS05	95	Z	FT glo	-3.6538E+00	-3.6538E+00
441	CS05	111	Z	FT glo	-7.3075E+00	-7.3075E+00
442	CS05	113	Z	FT glo	-7.3075E+00	-7.3075E+00
443	CS05	115	Z	FT glo	-7.3075E+00	-7.3075E+00
444	CS05	117	Z	FT glo	-7.3075E+00	-7.3075E+00
445	CS05	119	Z	FT glo	-7.3075E+00	-7.3075E+00
446	CS05	121	Z	FT glo	-3.6538E+00	-3.6538E+00
447	CS07	96	Z	FT glo	-3.6538E+00	-3.6538E+00
448	CS07	112	Z	FT glo	-7.3075E+00	-7.3075E+00
449	CS07	114	Z	FT glo	-7.3075E+00	-7.3075E+00
450	CS07	116	Z	FT glo	-7.3075E+00	-7.3075E+00
451	CS07	118	Z	FT glo	-7.3075E+00	-7.3075E+00
452	CS07	120	Z	FT glo	-7.3075E+00	-7.3075E+00
453	CS07	122	Z	FT glo	-3.6538E+00	-3.6538E+00
454	CS02	159	Z	FT glo	-3.9500E+00	-3.9500E+00
455	CS02	160	Z	FT glo	-3.9500E+00	-3.9500E+00
456	CS02	161	Z	FT glo	-7.9000E+00	-7.9000E+00
457	CS02	162	Z	FT glo	-7.9000E+00	-7.9000E+00
458	CS02	163	Z	FT glo	-7.9000E+00	-7.9000E+00
459	CS02	164	Z	FT glo	-7.9000E+00	-7.9000E+00
460	CS02	165	Z	FT glo	-7.9000E+00	-7.9000E+00
461	CS02	166	Z	FT glo	-7.9000E+00	-7.9000E+00
462	CS02	167	Z	FT glo	-7.9000E+00	-7.9000E+00
463	CS02	168	Z	FT glo	-7.9000E+00	-7.9000E+00
464	CS02	169	Z	FT glo	-7.9000E+00	-7.9000E+00
465	CS02	170	Z	FT glo	-7.9000E+00	-7.9000E+00
466	CS02	171	Z	FT glo	-3.9500E+00	-3.9500E+00
467	CS02	172	Z	FT glo	-3.9500E+00	-3.9500E+00
468	CS04	173	Z	FT glo	-3.9500E+00	-3.9500E+00
469	CS04	174	Z	FT glo	-3.9500E+00	-3.9500E+00

470	CS04	175	Z	FT glo	-7.9000E+00	-7.9000E+00
471	CS04	176	Z	FT glo	-7.9000E+00	-7.9000E+00
472	CS04	177	Z	FT glo	-7.9000E+00	-7.9000E+00
473	CS04	178	Z	FT glo	-7.9000E+00	-7.9000E+00
474	CS04	179	Z	FT glo	-7.9000E+00	-7.9000E+00
475	CS04	180	Z	FT glo	-7.9000E+00	-7.9000E+00
476	CS04	181	Z	FT glo	-7.9000E+00	-7.9000E+00
477	CS04	182	Z	FT glo	-7.9000E+00	-7.9000E+00
478	CS04	183	Z	FT glo	-7.9000E+00	-7.9000E+00
479	CS04	184	Z	FT glo	-7.9000E+00	-7.9000E+00
480	CS04	185	Z	FT glo	-3.9500E+00	-3.9500E+00
481	CS04	186	Z	FT glo	-3.9500E+00	-3.9500E+00
482	CS06	95	Z	FT glo	-3.9500E+00	-3.9500E+00
483	CS06	111	Z	FT glo	-7.9000E+00	-7.9000E+00
484	CS06	113	Z	FT glo	-7.9000E+00	-7.9000E+00
485	CS06	115	Z	FT glo	-7.9000E+00	-7.9000E+00
486	CS06	117	Z	FT glo	-7.9000E+00	-7.9000E+00
487	CS06	119	Z	FT glo	-7.9000E+00	-7.9000E+00
488	CS06	121	Z	FT glo	-3.9500E+00	-3.9500E+00
489	CS08	96	Z	FT glo	-3.9500E+00	-3.9500E+00
490	CS08	112	Z	FT glo	-7.9000E+00	-7.9000E+00
491	CS08	114	Z	FT glo	-7.9000E+00	-7.9000E+00
492	CS08	116	Z	FT glo	-7.9000E+00	-7.9000E+00
493	CS08	118	Z	FT glo	-7.9000E+00	-7.9000E+00
494	CS08	120	Z	FT glo	-7.9000E+00	-7.9000E+00
495	CS08	122	Z	FT glo	-3.9500E+00	-3.9500E+00
496		26	Z	FD glo	-4.8500E+00	
497		27	Z	FD glo	-4.8500E+00	
498		28	Z	FD glo	-4.8500E+00	
499		29	Z	FD glo	-4.8500E+00	
500		30	Z	FD glo	-4.8500E+00	
501		25	Z	FD glo	-4.8500E+00	
502		171	Z	FD glo	-4.8500E+00	
503		172	Z	FD glo	-4.8500E+00	
504		159	Z	FD glo	-4.8500E+00	
505		160	Z	FD glo	-4.8500E+00	
506		173	Z	FD glo	-4.8500E+00	
507		174	Z	FD glo	-4.8500E+00	
508		31	Z	FD glo	-4.8500E+00	
509		32	Z	FD glo	-4.8500E+00	
510		33	Z	FD glo	-4.8500E+00	
511		34	Z	FD glo	-4.8500E+00	
512		35	Z	FD glo	-4.8500E+00	
513		36	Z	FD glo	-4.8500E+00	
514		185	Z	FD glo	-4.8500E+00	
515		186	Z	FD glo	-4.8500E+00	
516		95	Z	FD glo	-1.2000E+00	
517		96	Z	FD glo	-1.2000E+00	
518		121	Z	FD glo	-1.2000E+00	
519		122	Z	FD glo	-1.2000E+00	
520	CS09	159	Z	FT glo	-9.8750E-01	-9.8750E-01
521	CS09	160	Z	FT glo	-9.8750E-01	-9.8750E-01
522	CS09	161	Z	FT glo	-1.9750E+00	-1.9750E+00
523	CS09	162	Z	FT glo	-1.9750E+00	-1.9750E+00
524	CS09	163	Z	FT glo	-1.9750E+00	-1.9750E+00
525	CS09	164	Z	FT glo	-1.9750E+00	-1.9750E+00
526	CS09	165	Z	FT glo	-1.9750E+00	-1.9750E+00
527	CS09	166	Z	FT glo	-1.9750E+00	-1.9750E+00
528	CS09	167	Z	FT glo	-1.9750E+00	-1.9750E+00
529	CS09	168	Z	FT glo	-1.9750E+00	-1.9750E+00
530	CS09	169	Z	FT glo	-1.9750E+00	-1.9750E+00
531	CS09	170	Z	FT glo	-1.9750E+00	-1.9750E+00
532	CS09	171	Z	FT glo	-9.8750E-01	-9.8750E-01
533	CS09	172	Z	FT glo	-9.8750E-01	-9.8750E-01
534	CS10	173	Z	FT glo	-9.8750E-01	-9.8750E-01
535	CS10	174	Z	FT glo	-9.8750E-01	-9.8750E-01

536	CS10	175	Z	FT glo	-1.9750E+00	-1.9750E+00
537	CS10	176	Z	FT glo	-1.9750E+00	-1.9750E+00
538	CS10	177	Z	FT glo	-1.9750E+00	-1.9750E+00
539	CS10	178	Z	FT glo	-1.9750E+00	-1.9750E+00
540	CS10	179	Z	FT glo	-1.9750E+00	-1.9750E+00
541	CS10	180	Z	FT glo	-1.9750E+00	-1.9750E+00
542	CS10	181	Z	FT glo	-1.9750E+00	-1.9750E+00
543	CS10	182	Z	FT glo	-1.9750E+00	-1.9750E+00
544	CS10	183	Z	FT glo	-1.9750E+00	-1.9750E+00
545	CS10	184	Z	FT glo	-1.9750E+00	-1.9750E+00
546	CS10	185	Z	FT glo	-9.8750E-01	-9.8750E-01
547	CS10	186	Z	FT glo	-9.8750E-01	-9.8750E-01

PESI PROPRI ASTE--|-----|-----|-----|-----|-----|-----|
 Cond. Nome Carichi Aste
 1 548-677 25-48, 67-93, 95-96, 111-187

CONDIZIONI DI CARICO-----|-----|-----|-----|num. = 11
 Nome

1	Peso proprio_____	N. carichi:	202
	Lista carichi: 382-453, 548-677		
2	Var.abitazione_____	N. carichi:	42
	Lista carichi: 454-495		
3	Masse sismiche_____	N. carichi:	52
	Lista carichi: 496-547		
4	EigenVector_001_(X)	N. carichi:	49
	Lista carichi: 1-49		
5	EigenVector_001_(Y)	N. carichi:	49
	Lista carichi: 50-98		
6	EigenVector_002_(X)	N. carichi:	45
	Lista carichi: 99-143		
7	EigenVector_002_(Y)	N. carichi:	49
	Lista carichi: 144-192		
8	Sisma_X_____	N. carichi:	49
	Lista carichi: 193-241		
9	Sisma_Y_____	N. carichi:	49
	Lista carichi: 242-290		
10	Torcente_add._X_____	N. carichi:	49
	Lista carichi: 291-339		
11	Torcente_add._Y_____	N. carichi:	42
	Lista carichi: 340-381		

DATI ANALISI SISMICA:

ANALISI DINAMICA

PARAMETRI DI CALCOLO:

accelerazione di gravita`	:	981.000
coefficiente di intensita` sismica	:	0.250
coefficiente di protezione	:	1.200
zona sismica	:	2
categoria del suolo	:	C
fattore "q"	:	3.750

autovettori calcolati : 2
 direzioni considerate : X Y

CONDIZIONI DI RIFERIMENTO	COEFFICIENTE	PESO RISULTANTE
1.	1.000	546228.114
2.	0.200	25411.807
3.	1.000	63894.560

*** TABELLA AUTOVETTORI ***

n	PERIODO [sec]	MASSA ATTIVATA			COEFFICIENTI DI CORRELAZIONE					n+6
		%X	%Y	%Z	n+1	n+2	n+3	n+4	n+5	
n+7										
1	0.377172	99.842	0.000	0.000	0.825					
2	0.360198	0.001	99.489	0.000						
-----		MASSA TOTALE 99.843 99.490 0.000			-----					

Non vengono documentate le sollecitazioni delle singole aste in quanto tali dati saranno ricavabili nelle verifiche riportate successivamente.

2 – VERIFICA DELLA STRUTTURA ALLO SLD

Nella verifica allo stato limite di danno è stato verificato che l'edificio nel suo complesso includendo anche gli elementi non strutturali non subisca danni gravi da interromperne l'utilizzo sotto un'azione sismica corrispondente ad un periodo di ritorno più basso come riportato in dettaglio nella relazione tecnica.

In particolare è stata effettuata una verifica degli spostamenti di interpiano assumendo come limite lo 0.5 %, limite ritenuto accettabile per tamponamenti rigidi come quelli previsti in progetto.

SPOSTAMENTI NODALI:

VERIFICA SPOSTAMENTI SISMICI

CASO DI VERIFICA n. 3

Zinf	Zsup	h	spost.max	%h	nodo	sest.	ver.
0.00	285.00	285.00	1.365512	0.479	55	1	SI

CASO DI VERIFICA n. 4

Zinf	Zsup	h	spost.max	%h	nodo	sest.	ver.
0.00	285.00	285.00	0.865153	0.304	50	1	SI

3 – VERIFICA DELLE TRAVI IN LEGNO LAMELLARE

3.1 Ipotesi di calcolo

Le strutture sono progettate per la *classe di servizio 1* che corrisponde ad una temperatura ambiente di 20°C ed una umidità relativa inferiore al 65% (strutture al chiuso).

I carichi variabili sono stati considerati di *breve durata* in quanto pur essendo superiori al carico neve in realtà sono stati assunti più alti in via cautelativa per la presenza di una copertura piana, ma non corrispondono ad un effettiva presenza di tali valori in esercizio.

In base a tali considerazioni nel calcolo è stato assunto:

$$\gamma_m = 1.35 \quad \gamma_{R,d} = 1.10$$

per cui la tensione ultima di calcolo a flessione è:

per le travi principali e i pilastri:

$$f_{m,y,d} = 28 / (1.35 \times 1.10) = 18.85 \text{ N/mm}^2$$

per le travi secondarie:

$$f_{m,y,d} = 24 / (1.35 \times 1.10) = 16.16 \text{ N/mm}^2$$

Per quanto riguarda il calcolo delle deformazioni si è assunto il coefficiente di amplificazione $K_{def} = 0.60$ (classe 1) per tenere in conto degli effetti viscosi dovuti ai carichi permanenti.

3.2 Verifica trave di copertura centinata

La verifica è condotta sia allo stato limite ultimo per la resistenza che allo stato limite di servizio per il calcolo delle deformazioni. Nelle verifiche si è tenuto conto dell'incremento di tensione dovuto alla curvatura della trave, ed alla presenza di tensioni residue per la piegatura delle lamelle.

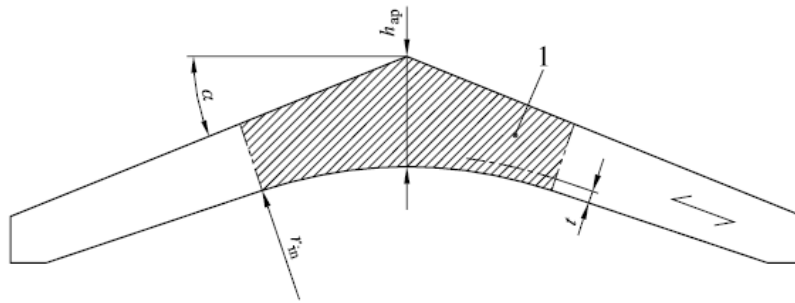

VERIFICA TRAVE CENTINATA SECONDO EN 1995/2005

Dati di progetto

Mslu	180.85	kN.m
hap	735	mm
b	220	mm
rin	7770	mm
alfa ap	16	°
lamelle	24	mm

rad 0.27925333
parametri

k1	1.84545047
k2	-1.9439687
k3	2.33865066
k4	0.49333993
r	8137.5

kl 1.68930882

Dati materiale

fmgk	28	N/mm ²	gammam	1.35
ft,90	0.45	N/mm ²	gammard	1.1
fvk	2.7	N/mm ²		
fc,90	5.5	N/mm ²		

sigma slt	18.86	N/mm ²
sigma t,90	0.30	N/mm ²
fvd	1.82	N/mm ²
fc,90,d	3.70	N/mm ²

rint/t 323.75

kr 1

sigma md 15.42 verificato

Resistenza al fuoco

min	60	velocità di carbonizzazione	0.7 mm/min
b	136 mm	sezione appoggio	
hap	693 mm	h	364 mm
Mfuoco	104.2 kN.m	base	220 mm
		hfuoco	322 mm
		basefuoco	136 mm
k1	1.90893576	Tfuoco	52.2 kN
k2	-2.0550579		
k3	2.3902856	tau	1.79 verificato
k4	0.54227847		
r	8137.5		
kl	1.89391343		
sigma md	18.13 verificato	tau	

Trazione ortogonale alla fibratura

k5	0.05734922
k6	0.0336615
k7	0.27327351
kp	0.06261902
kdis	1.7 trave centinata 1.7, doppia rastremazione e curve 1.4
Volume sollecitato	0.375 m3
kvol	0.48
sigmat,90	0.12 verificato

Taglio appoggio

T 87.15 kN

Compressione sull'appoggio

R 87.15 kN

appoggio

h 250 mm
b 250 mm

tau 1.63 verificato

sigma 1.12 N/mm² verificato

3.3 Verifica trave di copertura

La verifica è condotta ipotizzando uno schema statico di trave in semplice appoggio.

La verifica viene condotta sia allo stato limite ultimo che in esercizio.

VERIFICA TRAVE IN LEGNO LAMELLARE SECONDO EN 1995/2005

Dati di progetto

Mslu	212.625	kN.m
hap	601	mm
b	220	mm
lamelle	24	mm

Dati materiale

fmgk	28	N/mm ²	gamman	1.35
ft,90	0.45	N/mm ²	gammard	1.1
fvk	2.7	N/mm ²		
fc,90	5.5	N/mm ²		
E	12500	N/mm ²		
sigma sl	18.86	N/mm ²		
sigma t,90	0.30	N/mm ²		
fvd	1.82	N/mm ²		
fc,90,d	3.70	N/mm ²		

sigma md 16.05 verificato

sezione appoggio

h	364	mm
base	220	mm

Taglio appoggio

T 94.5 kN

tau 1.77 verificato

Compressione sull'appoggio

R 94.5 kN

appoggio

h	250	mm
b	250	mm

sigma 1.21 N/mm² verificato

Resistenza al fuoco

min	60		
b	136 mm	velocità di carbonizzazione	0.7 mm/min
hap	559 mm		
Mfuoco	111.375 kN.m		
sigma md	15.72 verificato		
Tfuoco	52.2 kN		
tau	1.79 verificato	hfuoco	322 mm
		basefuoco	136 mm

Verifica deformabilità trave appoggiata

q rara	4.6 kN/ml		
qqp	8 kN/ml		
luce	9.3 ml		
uist	9.01 mm	classe di servizio (1/2)	1
kdef	0.6		
udif	15.66		
utot	18.40 mm	"= L/"	505.3117

3.4 Verifica trave di copertura di bordo

La verifica è condotta ipotizzando uno schema statico di trave in semplice appoggio.
La verifica viene condotta sia allo stato limite ultimo che in esercizio.

VERIFICA TRAVE IN LEGNO LAMELLARE SECONDO EN 1995/2005

Dati di progetto

Mslu	17.31	kN.m
hap	501	mm
b	220	mm
lamelle	20	mm

Dati materiale

fmgk	28	N/mm ²
ft,90	0.45	N/mm ²
fvk	2.7	N/mm ²
fc,90	5.5	N/mm ²
E	12500	N/mm ²

gammam	1.35
gammard	1.1

sigma slv	18.86	N/mm ²
sigma t,90	0.30	N/mm ²
fvd	1.82	N/mm ²
fc,90,d	3.70	N/mm ²

sigma md 1.88 verificato

sezione appoggio

h	364	mm
base	220	mm

Taglio appoggio

T 77.78 kN

intaglio da verificare (1/0) 0

kv 0.28

inclinazione 0

rad 0

distanza reaz 400 mm

tau 1.46 verificato

Compressione sull'appoggio

R 77.78 kN

appoggio

h	250	mm
b	250	mm

sigma 1.00 N/mm² verificato

Resistenza al fuoco

min 60

b 178 mm
hap 459 mm

velocità di carbonizzazione 0.7 mm/min

Mfuoco 10.89 kN.m

sigma md 1.74 verificato

Tfuoco	52.2 kN	hfuoco	322 mm
tau	1.79 verificato	basefuoco	136 mm

Verifica deformabilità trave appoggiata

q rara	10.25 kN/ml		
qqp	9 kN/ml		
luce	7 ml		
uist	11.12 mm	classe di servizio (1/2)	1
kdef	0.6		
udif	9.76		
utot	16.98 mm	"= L'"	412.3038437

3.5 Verifica travi secondarie

VERIFICA TRAVE IN LEGNO LAMELLARE SECONDO EN 1995/2005

Dati di progetto

Mslu	11.22 kN.m
hap	230 mm
b	160 mm
lamelle	20 mm

Dati materiale

fmgk	24 N/mm ²
ft,90	0.45 N/mm ²
fvk	2.7 N/mm ²
fc,90	5.5 N/mm ²
E	12500 N/mm ²

gammam	1.35
gammard	1.1

sigma sl	16.16 N/mm ²
sigma t,90	0.30 N/mm ²
fvd	1.82 N/mm ²
fc,90,d	3.70 N/mm ²

sigma md	7.95 verificato
----------	-----------------

sezione appoggio

h 230 mm
base 120 mm

Taglio appoggio

T 11.22 kN

Compressione sull'appoggio

R 11.22 kN

appoggio

h 200 mm
b 100 mm

tau 0.61 verificato

sigma 0.45 N/mm² verificato

Resistenza al fuoco

min 60

b 76 mm
hap 188 mm

velocità di carbonizzazione 0.7 mm/min

Mfuoco 5.8 kN.m

sigma md 12.96 verificato

Tfuoco 5.08 kN

tau 1.13 verificato

hfuoco 188 mm
basefuoco 36 mm

Verifica deformabilità trave appoggiata

q rara 3.85 kN/ml
qqp 1.9 kN/ml
luce 4 ml

uist 6.33 mm

classe di servizio (1/2) 1

kdef 0.6

udif 3.12

utot 8.20 mm

"= L'" 487.6553

3.6 Verifica tavolato

Dati di progetto

Mslu	0.7	kN.m
hap	30	mm
b	1000	mm
lamelle	20	mm

Dati materiale

fmgk	24	N/mm ²
ft,90	0.45	N/mm ²
fvk	2.7	N/mm ²
fc,90	5.5	N/mm ²
E	12500	N/mm ²

gammam	1.35
gammard	1.1

sigma sl _u	16.16	N/mm ²
sigma t,90	0.30	N/mm ²
fvd	1.82	N/mm ²
fc,90,d	3.70	N/mm ²

sigma md 4.67 verificato

3.7 Verifica giunzione travi in legno lamellare

Si verifica la capacità dei bulloni di trasmettere l'azione sismica ai pilastri.

Taglio sismico da trasmettere = 114 kN

VERIFICA CONNESSIONE ACCIAIO-LEGNO CON BULLONI

MODALITA' A DOPPIO TAGLIO

Spessore legno	220	mm
angolo alfa soll.	0	°
rad	0	
spessore piastra metal	10	mm

Dati Legname

fmgk	28	N/mm ²
ft,90	0.45	N/mm ²
fvk	2.7	N/mm ²
fc,90	5.5	N/mm ²
ro	400	kg/m ³

gammam	1.35
gammard	1.1

sigma sl _u	18.86	N/mm ²
sigma t,90	0.30	N/mm ²
fvd	1.82	N/mm ²
fc,90,d	3.70	N/mm ²

Dati bullone

fuk	500 N/mm ²
gamman	1.1
fud	454.55 N/mm ²
diametro bullone	16 mm
Momento di snervamento	184251.3 N.mm
Resistenza rifollamento legno	27.552 N/mm ²
piastra sottile?	no
piastra spessa?	no
Calcolo per piastra sottile	
Fvrk	14.66 kN
Calcolo per piastra spessa	
Fvrk	20.73 kN
Piastra intermedia	16.18 kN

Il valore di 16.18 kN si riferisce al singolo bullone per cui la resistenza del collegamento vale:
 $F_r = 8 \times 16.18 = 129.5 \text{ kN} > F$ sollecitante

3.9 Verifica pilastro in legno lamellare

I pilastri in legno lamellare sono stati calcolati a solo sforzo normale in quanto sono stati considerati come elementi pendolari incernierati sia in testa che alla base.

Sezione 35 x 25 cm

$N_{slu} = 165 \text{ kN}$

$\beta_c = 0.1$ (legno lamellare)

$\lambda_{rel,y} = 0.65$

$K_y = 0.73$ $K_{cy} = 0.94$

$$16500 / (0.94 \times 35 \times 25 \times 185) = 0.1 \ll 1$$

3.10 Verifica elementi di controventi metallici

Dall'analisi globale della struttura considerando gli elementi di controvento reagenti solo a trazione si ottiene la massima azione sotto sisma pari a 25 kN.

Verifica della tensione:

$$\sigma = 2500 / (10 - 1.7) \times .6 = 500 \text{ kg/cm}^2 \ll F_y$$

4 - VERIFICA DEI PILASTRI IN C.A.

PILASTRI 25 X 65

SLU

Tipo verifica : stati limite - pressoflessione deviata.

Unità di misura: Kgf; cm; Kgf / cm²; Kgf x cm; d in mm; deformazioni*1000.

Simboli:

Vert. = contorno_vertice del CLS; d = diametro;
 S = Sigma (tensioni sui materiali);
 D = Deformazioni x 1000 (epsilon);
 Ve = colonna che indica se la verifica e' soddisfatta;

MATERIALI

Calcestruzzo: Rck = 350. ; fck = 290.5 ; fcd = 0. .
 Acciaio : Tipo= FeB44k ; ftk = 4972. ; fyk = 4972. ; fyd = 0.
 .

SEZIONE

L'asse Z e' rivolto verso destra, l'asse Y e' rivolto verso l'alto.

Tipo sezione: RETTANGOLARE

Cls:

Cls:		Acciaio lento:					
vert.	Z	Y	ferro	Z	Y	d[mm]	Af[cm ²]
1_ 1	-12.5	65.	1	-7.5	18.8	20.	3.1416
1_ 2	12.5	65.	2	-7.5	32.5	20.	3.1416
1_ 3	12.5	0.	3	-7.5	46.3	20.	3.1416
1_ 4	-12.5	0.	4	7.5	46.3	20.	3.1416
			5	7.5	32.5	20.	3.1416
			6	7.5	18.8	20.	3.1416
			7	7.5	60.	24.	4.5239
			8	0.	60.	24.	4.5239
			9	-7.5	60.	24.	4.5239
			10	-7.5	5.	24.	4.5239
			11	0.	5.	24.	4.5239
			12	7.5	5.	24.	4.5239

SOLLECITAZIONI AGENTI

Sforzi normali applicati in z= 0. ; y= 32.5 (baricentro CLS)

Convenzioni: N + trazione; Mz + fib.inferiori tese; My + fib.sinistra tese.

N.	N	Mz	My	Sollecitaz. ultima calcolata
1	-18550	-4943633	-138549	
2	-15928	4925320	164950	
3	-8121	-1772429	-540876	
4	-8120	-149851	552104	
5	-39083	-1320196	855	

6 | -6962 | -72 | 63 |

RISULTATI

Piani di equilibrio (eps= muz * y +muy * z + lam):

Sol.	muz	muy	lambda
1	.00010034885	.00002898566	-.00218377081
2	-.00010439777	-.00003516332	.00456878727
3	.00002429942	.00006666345	-.00048781335
4	.00000192849	-.00006693306	.00016685802
5	.00001320524	-.00000007376	-.00047170976
6	.00000000048	-.00000000325	-.00001809201

Deformazioni massime sui materiali:

sol	Cls				Acciaio lento			
	vert.	D cls	S cls	Ve	ferro	D ferri	S ferri	Ve
1	1- 4	-2.5461	-181.2	si	7	4.0546	4324.5	si
2	1- 2	-2.6566	-181.2	si	10	4.3105	4324.7	si
3	1- 4	-1.3211	-160.3	si	7	1.4701	2940.3	si
4	1- 3	-.6698	-101.1	si	9	.7846	1569.1	si
5	1- 3	-.4726	-75.5	si	9	.3212	642.3	si
6	1- 3	-.0181	-3.3	si	9	-.018	-36.1	si

In base al criterio dell'alta duttilità si verifica a taglio il pilastro con un incremento dell'azione sismica del 20%.

Caratteristiche della sezione

base 250 mm
 altezza ut 600 mm
 Ar.Fer. Long. 1570 mmq

Caratteristiche del materiale

Cls Fck 28 MPa
 Acciaio fy 430 MPa

VERIFICA SENZA ARMATURE TRASVERSALI

Azioni di compressione sulla sezione

20000 N

sigma cp 0.13 MPa

Taglio resistente

Vrd,c 85.07 kN valore min 58.03 kN

VERIFICA CON ARMATURE TRASVERSALI solo staffe

cotg teta 2.5 Diam.barre 8 mm
 Passo 150 mm
 bracci 2

Vrd,s **338.31** kN alfac 1.00

Vrd, max **571.96** kN

verifica armatura massima

Asw **3.11** presente **0.67** mmq/mm

RARA

Tipo verifica : tensioni ammissibili - pressoflessione deviata.
Unità di misura: Kgf; cm; Kgf / cm²; Kgf x cm; d in mm; deformazioni*1000.
Simboli:

Vert. = contorno_vertice del CLS; d = diametro;
S = Sigma (tensioni sui materiali);
Ve = colonna che indica se la verifica e' soddisfatta.

MATERIALI

Calcestruzzo: Rck = 350. ; fck = 290.5 ; fcd = 0. .
Acciaio : Tipo= FeB44k ; ftk = 4972. ; fyk = 4972. ; fyd = 0.

SEZIONE

L'asse Z e' rivolto verso destra, l'asse Y e' rivolto verso l'alto.
Tipo sezione: RETTANGOLARE

Cls:	Acciaio lento:						
vert.	Z	Y	ferro	Z	Y	d[mm]	Af[cm ²]
1_ 1	-12.5	65.	1	-7.5	18.8	20.	3.1416
1_ 2	12.5	65.	2	-7.5	32.5	20.	3.1416
1_ 3	12.5	0.	3	-7.5	46.3	20.	3.1416
1_ 4	-12.5	0.	4	7.5	46.3	20.	3.1416
			5	7.5	32.5	20.	3.1416
			6	7.5	18.8	20.	3.1416
			7	7.5	60.	24.	4.5239
			8	0.	60.	24.	4.5239
			9	-7.5	60.	24.	4.5239
			10	-7.5	5.	24.	4.5239
			11	0.	5.	24.	4.5239
			12	7.5	5.	24.	4.5239

SOLLECITAZIONI AGENTI

Sforzi normali applicati in z= 0. ; y= 32.5 (baricentro CLS)
Convenzioni: N + trazione; Mz + fib.inferiori tese; My + fib.sinistra tese.

N.	N	Mz	My	Sollecitaz. ultima calcolata
1	-22772	-1908276	-2064	
2	-21889	1907447	-2201	
3	-9542	1138641	-32516	
4	-9542	1170388	35016	
5	-27328	-919689	590	
6	-8384	-175	66	

RISULTATI

Piani di equilibrio (eps= muz * y +muy * z + lam):

Sol.	muz	muy	lambda
1	.00000925565	.00000008421	-.00026196705
2	-.00000929486	.00000009017	.000343041
3	-.00000572582	.00000136999	.00021945229
4	-.00000589893	-.00000147837	.00022669469
5	.00000370943	-.00000002057	-.000138527
6	.00000000054	-.00000000159	-.00001014357

Tensioni massime sui materiali:

sol	Cls			Acciaio lento		
	vert.	S cls	Ve	ferro	S ferri	Ve
1	1- 4	-96.	si	7	1609.3	si
2	1- 1	-95.7	si	12	1627.	si
3	1- 1	-62.	si	12	1100.8	si
4	1- 2	-63.9	si	10	1140.1	si
5	1- 3	-50.6	si	12	-657.6	si
6	1- 3	-3.7	si	12	-55.6	si

PILASTRO 25X50

Tipo verifica : stati limite - pressoflessione deviata.

Unità di misura: Kgf; cm; Kgf / cm²; Kgf x cm; d in mm; deformazioni*1000.

Simboli:

Vert. = contorno_vertice del CLS; d = diametro;
 S = Sigma (tensioni sui materiali);
 D = Deformazioni x 1000 (epsilon);
 Ve = colonna che indica se la verifica e' soddisfatta;

MATERIALI

Calcestruzzo: Rck = 350. ; fck = 290.5 ; fcd = 0. .
 Acciaio : Tipo= FeB44k ; ftk = 4972. ; fyk = 4972. ; fyd = 0.8 .

SEZIONE

L'asse Z e' rivolto verso destra, l'asse Y e' rivolto verso l'alto.

Tipo sezione: RETTANGOLARE

vert.	Cls			Acciaio lento:				
	Z	Y		ferro	Z	Y	d[mm]	Af[cm ²]
1_ 1	-25.	25.		1	20.	20.	24.	4.5239
1_ 2	25.	25.		2	6.7	20.	20.	3.1416
1_ 3	25.	0.		3	-6.7	20.	20.	3.1416
1_ 4	-25.	0.		4	-20.	20.	24.	4.5239
				5	-20.	5.	24.	4.5239
				6	-6.7	5.	20.	3.1416
				7	6.7	5.	20.	3.1416
				8	20.	5.	24.	4.5239

SOLLECITAZIONI AGENTI

Sforzi normali applicati in z= 0. ; y= 32.5 (baricentro CLS)

Convenzioni: N + trazione; Mz + fib.inferiori tese; My + fib.sinistra tese.

N.	N	Mz	My	Sollecitaz. ultima calcolata
1	-21189	-604042	-465548	
2	-19333	601052	545762	
3	-10565	-273990	-1725731	
4	-9933	0	1751680	
5	-39184	-351575	-15345	
6	-7642	77	439	

RISULTATI

Piani di equilibrio (eps= muz * y +muy * z + lam):

Sol.	muz	muy	lambda
1	.00008768606	.00001546473	-.00087123364
2	-.00008876997	-.00001834408	.00135719228
3	.0000429755	.00006554806	-.00006716154
4	0.	-.00006612388	.0004678205
5	.00003300368	.00000037273	-.00051290618
6	-.0000000051	-.00000000706	-.00002662439

Deformazioni massime sui materiali:

sol	Cls	vert.	Classe			Acciaio lento			
			D cls	S cls	Ve	ferro	D ferri	S ferri	Ve
1	1- 4	-1.2579	-156.3	si	1	1.1918	2383.6	si	
2	1- 2	-1.3207	-160.3	si	5	1.2802	2560.4	si	
3	1- 4	-1.7059	-177.3	si	1	2.1033	4206.6	si	
4	1- 2	-1.1853	-151.2	si	5	1.7903	3580.6	si	
5	1- 4	-.5222	-82.3	si	1	.1546	309.2	si	
6	1- 2	-.0269	-4.8	si	5	-.0265	-53.	si	

VERIFICA A TAGLIO SECONDO EN 1992 1-1

Caratteristiche della sezione

base 250 mm
 altezza ut 450 mm
 Ar.Fer. Long. 1570 mmq

Caratteristiche del materiale

Cls Fck 28 MPa
 Acciaio fy 430 MPa

VERIFICA SENZA ARMATURE TRASVERSALI

Azioni di compressione sulla sezione

100000 N

sigma cp 0.89 MPa

Taglio resistente

Vrd,c 86.58 kN valore min 59.83 kN

VERIFICA CON ARMATURE TRASVERSALI solo staffe

cotg teta 2 Diam.barre 8 mm
 Passo 150 mm
 bracci 2

Vrd,s 202.99 kN alfac 1.02

Vrd, max 505.97 kN

verifica armatura massima

Asw **3.16** presente **0.67** mmq/mm

RARA

Tipo verifica : tensioni ammissibili - pressoflessione deviata.
Unità di misura: Kgf; cm; Kgf / cm²; Kgf x cm; d in mm; deformazioni*1000.
Simboli:

Vert. = contorno_vertice del CLS; d = diametro;
S = Sigma (tensioni sui materiali);
Ve = colonna che indica se la verifica e' soddisfatta.

MATERIALI

Calcestruzzo: Rck = 350. ; fck = 290.5 ; fcd = 0. .
Acciaio : Tipo= FeB44k ; ftk = 4972. ; fyk = 4972. ; fyd = 0.

SEZIONE

L'asse Z e' rivolto verso destra, l'asse Y e' rivolto verso l'alto.

Tipo sezione: RETTANGOLARE

Cls:		Acciaio lento:					
vert.	Z	Y	ferro	Z	Y	d[mm]	Af[cm ²]
1_ 1	-25.	25.	1	20.	20.	24.	4.5239
1_ 2	25.	25.	2	6.7	20.	20.	3.1416
1_ 3	25.	0.	3	-6.7	20.	20.	3.1416
1_ 4	-25.	0.	4	-20.	20.	24.	4.5239
			5	-20.	5.	24.	4.5239
			6	-6.7	5.	20.	3.1416
			7	6.7	5.	20.	3.1416
			8	20.	5.	24.	4.5239

SOLLECITAZIONI AGENTI

Sforzi normali applicati in z= 0. ; y= 12.5 (baricentro CLS)
Convenzioni: N + trazione; Mz + fib.inferiori tese; My + fib.sinistra tese.

N.	N	Mz	My	Sollecitaz. ultima calcolata
1	-26254	244832	-9447	
2	-12776	0	-19997	
3	-12776	0	26905	
4	-27399	-244918	-10663	
5	-11885	-400	-9	

RISULTATI

Piani di equilibrio (eps= muz * y +muy * z + lam):

Sol.	muz	muy	lambda
1	-.00000968044	.00000009371	.00009033086
2	0.	.00000014828	-.00002084885
3	0.	-.0000001995	-.00002084885
4	.00000950109	.00000010427	-.00015248134
5	.00000001228	.00000000007	-.00001954837

Tensioni massime sui materiali:

Cls			Acciaio lento			
sol	vert.	S cls	Ve	ferro	S ferri	Ve
1	1- 1	-56.2	si	4	-575.6	si
2	1- 4	-9.	si	5	-130.4	si

3	1- 3	-9.4	si	8	-136.	si
4	1- 4	-56.6	si	5	-586.	si
5	1- 4	-7.1	si	5	-106.7	si

PARETE DEL PORTALE DI FACCIATA

Slu

Tipo verifica : stati limite - pressoflessione deviata.

Unità di misura: Kgf; cm; Kgf / cm²; Kgf x cm; d in mm; deformazioni*1000.

Simboli:

Vert. = contorno_vertice del CLS; d = diametro;
 S = Sigma (tensioni sui materiali);
 D = Deformazioni x 1000 (epsilon);
 Ve = colonna che indica se la verifica e' soddisfatta;

MATERIALI

Calcestruzzo: Rck = 350. ; fck = 249. ; fcd = 155.63.
 Acciaio : Tipo= FeB44k ; ftk = 4400. ; fyk = 4400. ; fyd = 3826.09

SEZIONE

L'asse Z e' rivolto verso destra, l'asse Y e' rivolto verso l'alto.

Tipo sezione: RETTANGOLARE

Cls:

Acciaio lento:

vert.	Z	Y	ferro	Z	Y	d[mm]	Af[cm ²]
1_ 1	-12.5	40.	1	8.9	3.6	16.	2.0106
1_ 2	12.5	40.	2	8.9	14.5	16.	2.0106
1_ 3	12.5	0.	3	8.9	25.5	16.	2.0106
1_ 4	-12.5	0.	4	8.9	36.4	16.	2.0106
			5	-8.9	36.4	16.	2.0106
			6	-8.9	25.5	16.	2.0106
			7	-8.9	14.5	16.	2.0106
			8	-8.9	3.6	16.	2.0106

SOLLECITAZIONI AGENTI

Sforzi normali applicati in z= 0. ; y= 20. (baricentro CLS)

Convenzioni: N + trazione; Mz + fib.inferiori tese; My + fib.sinistra tese.

N.	N	Mz	My	Sollecitaz. ultima calcolata
1	-3414	-328894	162279	
2	-3574	145771	-540930	
3	-3574	145771	540930	
4	-3872	915594	162279	Mz+:915594/1027291= .8913
5	-2513	0	0	

RISULTATI

Piani di equilibrio (eps= muz * y +muy * z + lam):

Sol.	muz	muy	lambda
1	.00003597792	-.0000363304	-.00046515914
2	-.00001733447	.00013719	.00090869208
3	-.00001733447	-.00013719	.00090869208
4	-.0002072259	-.00008606773	.00586741051
5	0.	0.	-.00001532838

Deformazioni massime sui materiali:

sol	Cls				Acciaio lento			
	vert.	D cls	S cls	Ve	ferro	D ferri	S ferri	Ve
1	1- 3	-.9193	-93.7	si	5	1.1678	2335.6	si
2	1- 1	-1.4996	-124.	si	1	2.0673	3826.2	si

3	1- 2	-1.4996	-124.	si	8	2.0673	3826.2	si
4	1- 2	-3.4975	-132.3	si	8	5.8874	3828.	si
5	1- 1	-.0153	-2.	si	1	-.0153	-30.7	si

5- VERIFICA DELLE FONDAZIONI

5.1 Verifica pressioni in fondazione

Combinazione SLU (calcolata con $q = 1.5$ criterio alta duttilità)

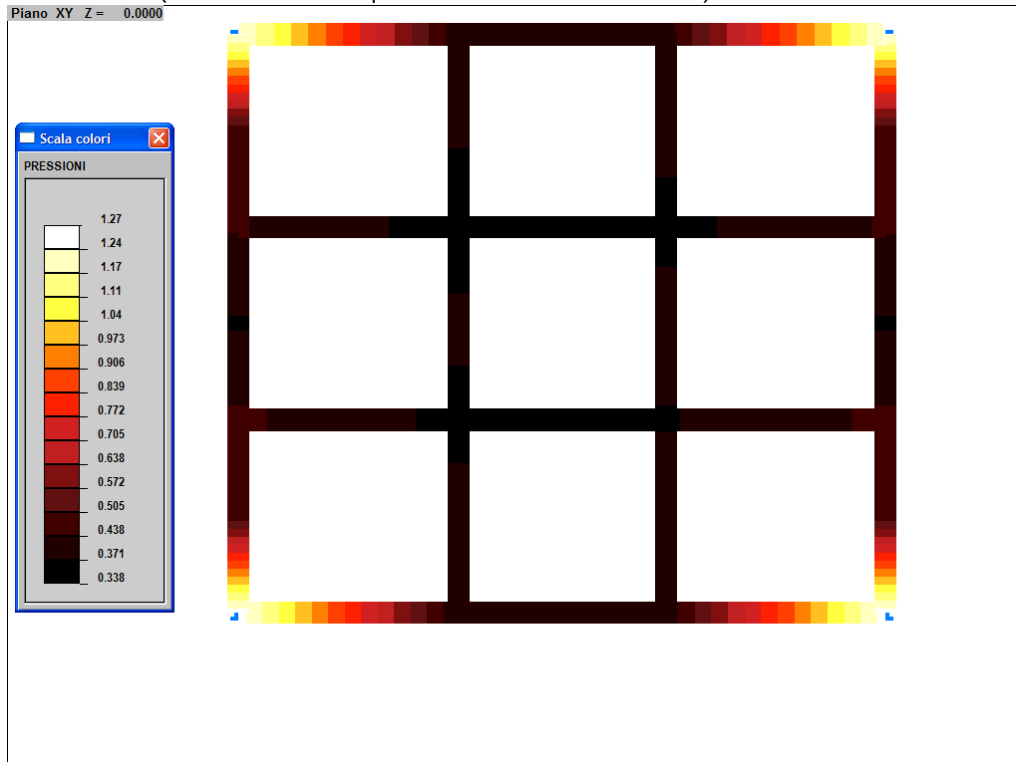

Pressione massima 1.3 kg/cm² << 3.8 kg/cm² = pressione ultima

Combinazione GEO (G+1.3 Q)

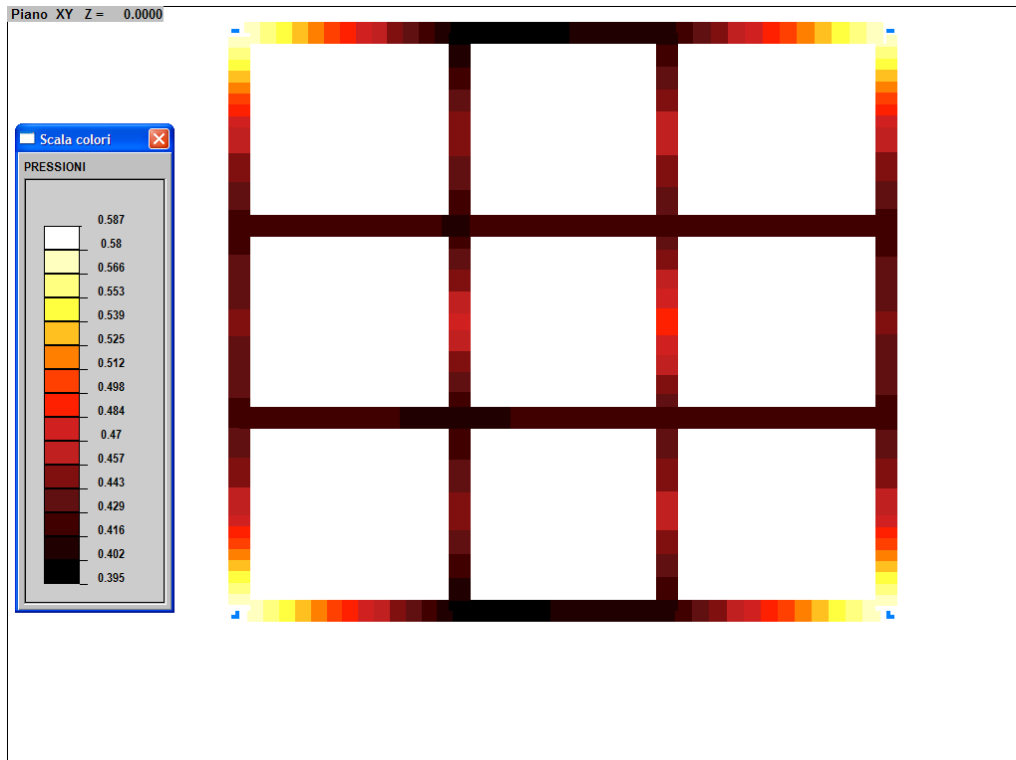

Pressione massima 0.6 kg/cmq (vedi relazione geotecnica per la verifica a capacità portante)

5.2 Verifica travi di fondazione

In base al criterio dell'alta duttilità si verificano le fondazioni allo SLU con le sollecitazioni date dai momenti resistenti dei pilastri superiori.
Per le verifiche in esercizio si utilizzano le sollecitazioni trasmesse dai carichi superiori.

Trave filo 1 e 7

Metodo di verifica : stati limite.
Unità di misura : KgF; cm; cm2; KgF/cm; KgFcm; KgF/cm2; (ferri: mm; cm2);
deform.*1000.

MATERIALI

CLS : Rck =300. ; fck=249. ; fctk= 18.4; fctm= 26.2; Ec= 311769. ;
gc =1.6 ; fcd=155.6; fbd= 25.8; fctd= 11.5; EpsMax=3.5
ACCIAIO: FeB44k; fk(1%)=4383.3; fyk=4383.3; Ea=2050000. ;
ga =1.15; fyd=3811.5; EpsMax=10.

TENSIONI E FESSURE MASSIME IN ESERCIZIO

GRUPPO : a (poco aggressivo).
CLS : Scls(rara)=149.4; Scls(quasi permanente)=112. ; fbd(esercizio)= 25.8
ACCIAIO: Sacc(rara)=3068.; Coeff.Omogein.= 15
FESSURE: Wk(rara)=*** ; Wk(fre.)=.4 ; Wk(q.p.)=.2 ;
c/cmin= 1 [Circ. 15/10/96 N.252 B.6.2]; kt=.4 [EN 1992-1 7.3.4].

SEZIONI UTILIZZATE

3) A T rovescio: largh.=100; alt.=80; sp.ala=30; sp.an.=50; Acls=5500 .

DESCRIZIONE CAMPATE

Cam.	Descriz.	S.ini	Sez.	S.fin	Incl.	L.assi	L.netta
1	A132	3	3	3	0	900.	835.
2	A133	3	3	3	0	850.	785.

3 | A134 | 3 | 3 | 3 | 0 | 900. | 835. |

CASI DI CARICO DA MODELLO 3D

SLU			RARE			QUASI PERMANENTI		
Nome	Descrizione	Sest	Nome	Descrizione	Sest	Nome	Descrizione	Sest
9.	Fondazioni	2.						

VERIFICHE ALLO STATO LIMITE ULTIMO

FLESSIONE:

Progressive	SE	Ar	Msd	Epscl	Epsac	Mrd	Epscl	Epsac	Cam	x/d	Mr/Ms	VE	
> 0.	0.	3.	1.	-5036659.	-.516	1.814	-5330939.	-1.1	10.	2.	.099	1.058	SI
0.	0.	3.	1.	5036659.	-.723	1.779	5475774.	-1.45	10.	2.	.127	1.087	SI
20.	20.	3.	1.	-5036659.	-.516	1.814	-5330939.	-1.1	10.	2.	.099	1.058	SI
20.	20.	3.	1.	5036659.	-.723	1.779	5475774.	-1.45	10.	2.	.127	1.087	SI
39.	39.	3.	1.	-4962350.	-.508	1.787	-5330939.	-1.1	10.	2.	.099	1.074	SI
39.	39.	3.	1.	4962350.	-.712	1.752	5475774.	-1.45	10.	2.	.127	1.103	SI
87.	87.	3.	1.	-4164066.	-.423	1.499	-5330939.	-1.1	10.	2.	.099	1.28	SI
87.	87.	3.	1.	4164066.	-.591	1.469	5475774.	-1.45	10.	2.	.127	1.315	SI
136.	136.	3.	1.	-3380766.	-.341	1.216	-5330939.	-1.1	10.	2.	.099	1.577	SI
136.	136.	3.	1.	3380766.	-.475	1.192	5475774.	-1.45	10.	2.	.127	1.62	SI
184.	184.	3.	1.	-2651459.	-.265	.953	-5330939.	-1.1	10.	2.	.099	2.011	SI
184.	184.	3.	1.	2651459.	-.369	.934	5475774.	-1.45	10.	2.	.127	2.065	SI
233.	233.	3.	1.	-1970293.	-.196	.708	-5330939.	-1.1	10.	2.	.099	2.706	SI
233.	233.	3.	1.	1970293.	-.272	.694	5475774.	-1.45	10.	2.	.127	2.779	SI
281.	281.	3.	2.	-1348665.	-.169	.723	-3567091.	-.971	10.	2.	.089	2.645	SI
281.	281.	3.	2.	1348665.	-.252	.907	2843699.	-1.07	10.	2.	.097	2.109	SI
329.	329.	3.	2.	-829960.	-.103	.445	-3567091.	-.971	10.	2.	.089	4.298	SI
329.	329.	3.	2.	829960.	-.154	.558	2843699.	-1.07	10.	2.	.097	3.426	SI
378.	378.	3.	2.	-440330.	-.055	.236	-3567091.	-.971	10.	2.	.089	8.101	SI
378.	378.	3.	2.	440330.	-.081	.296	2843699.	-1.07	10.	2.	.097	6.458	SI
426.	426.	3.	2.	-515619.	-.064	.276	-3567091.	-.971	10.	2.	.089	6.918	SI
426.	426.	3.	2.	515619.	-.095	.347	2843699.	-1.07	10.	2.	.097	5.515	SI
474.	474.	3.	2.	-704371.	-.088	.378	-3567091.	-.971	10.	2.	.089	5.064	SI
474.	474.	3.	2.	704371.	-.13	.474	2843699.	-1.07	10.	2.	.097	4.037	SI
523.	523.	3.	2.	-908121.	-.113	.487	-3567091.	-.971	10.	2.	.089	3.928	SI
523.	523.	3.	2.	908121.	-.169	.611	2843699.	-1.07	10.	2.	.097	3.131	SI
571.	571.	3.	2.	-1055524.	-.132	.566	-3567091.	-.971	10.	2.	.089	3.379	SI
571.	571.	3.	2.	1055524.	-.196	.71	2843699.	-1.07	10.	2.	.097	2.694	SI
619.	619.	3.	2.	-1182356.	-.148	.634	-3567091.	-.971	10.	2.	.089	3.017	SI
619.	619.	3.	2.	1182356.	-.22	.795	2843699.	-1.07	10.	2.	.097	2.405	SI
668.	668.	3.	2.	-1275747.	-.16	.684	-3567091.	-.971	10.	2.	.089	2.796	SI
668.	668.	3.	2.	1275747.	-.238	.858	2843699.	-1.07	10.	2.	.097	2.229	SI
716.	716.	3.	3.	-1349792.	-.144	.55	-4696316.	-1.06	10.	2.	.095	3.479	SI
716.	716.	3.	3.	1349792.	-.202	.565	4599379.	-1.35	10.	2.	.119	3.407	SI
764.	764.	3.	3.	-1398681.	-.149	.57	-4696316.	-1.06	10.	2.	.095	3.358	SI
764.	764.	3.	3.	1398681.	-.209	.585	4599379.	-1.35	10.	2.	.119	3.288	SI
813.	813.	3.	3.	-1417398.	-.151	.578	-4696316.	-1.06	10.	2.	.095	3.313	SI
813.	813.	3.	3.	1417398.	-.212	.593	4599379.	-1.35	10.	2.	.119	3.245	SI
861.	861.	3.	3.	-1427743.	-.152	.582	-4696316.	-1.06	10.	2.	.095	3.289	SI
861.	861.	3.	3.	1427743.	-.214	.597	4599379.	-1.35	10.	2.	.119	3.221	SI
881.	881.	3.	3.	-1428706.	-.152	.582	-4696316.	-1.06	10.	2.	.095	3.287	SI
881.	881.	3.	3.	1428706.	-.214	.598	4599379.	-1.35	10.	2.	.119	3.219	SI
900.	900.	3.	3.	-1428706.	-.152	.582	-4696316.	-1.06	10.	2.	.095	3.287	SI
900.	900.	3.	3.	1428706.	-.214	.598	4599379.	-1.35	10.	2.	.119	3.219	SI
> 900.	0.	3.	3.	-4225574.	-.463	1.726	-4696316.	-1.06	10.	2.	.095	1.111	SI
900.	0.	3.	3.	4225574.	-.657	1.773	4599379.	-1.35	10.	2.	.119	1.088	SI
920.	20.	3.	3.	-4225574.	-.463	1.726	-4696316.	-1.06	10.	2.	.095	1.111	SI
920.	20.	3.	3.	4225574.	-.657	1.773	4599379.	-1.35	10.	2.	.119	1.088	SI
939.	39.	3.	3.	-4149074.	-.454	1.694	-4696316.	-1.06	10.	2.	.095	1.132	SI
939.	39.	3.	4.	4149074.	-.543	1.715	4614972.	-1.1	10.	2.	.099	1.112	SI
987.	87.	3.	4.	-3329261.	-.294	.788	-8173761.	-1.51	10.	2.	.131	2.455	SI
987.	87.	3.	4.	3329261.	-.432	1.376	4614972.	-1.1	10.	2.	.099	1.386	SI
1036.	136.	3.	3.	-2539405.	-.274	1.036	-4696316.	-1.06	10.	2.	.095	1.849	SI
1036.	136.	3.	3.	2539405.	-.385	1.064	4599379.	-1.35	10.	2.	.119	1.811	SI
1084.	184.	3.	3.	-1845267.	-.197	.752	-4696316.	-1.06	10.	2.	.095	2.545	SI
1084.	184.	3.	5.	1845267.	-.327	1.236	2846295.	-.994	10.	2.	.09	1.542	SI
1132.	232.	3.	2.	-1222808.	-.153	.656	-3567091.	-.971	10.	2.	.089	2.917	SI
1132.	232.	3.	2.	1222808.	-.228	.823	2843699.	-1.07	10.	2.	.097	2.326	SI
1180.	280.	3.	2.	-690934.	-.086	.37	-3567091.	-.971	10.	2.	.089	5.163	SI
1180.	280.	3.	2.	690934.	-.128	.465	2843699.	-1.07	10.	2.	.097	4.116	SI
1229.	328.	3.	6.	-286720.	-.033	.153	-3570591.	-.862	10.	2.	.079	12.45	SI
1229.	328.	3.	6.	286720.	-.042	.099	5622705.	-1.69	10.	2.	.145	19.61	SI

1277.	377.	3.	6.	-584249.	-.066	.311	-3570591.	-.862	10.	2.	.079	6.111	SI
1277.	377.	3.	6.	584249.	-.085	.201	5622705.	-1.69	10.	2.	.145	9.624	SI
1325.	425.	3.	6.	-796472.	-.091	.424	-3570591.	-.862	10.	2.	.079	4.483	SI
1325.	425.	3.	6.	796472.	-.117	.275	5622705.	-1.69	10.	2.	.145	7.06	SI
1373.	473.	3.	2.	-975275.	-.122	.523	-3567091.	-.971	10.	2.	.089	3.658	SI
1373.	473.	3.	2.	975275.	-.181	.656	2843699.	-1.07	10.	2.	.097	2.916	SI
1422.	521.	3.	2.	-1110974.	-.139	.596	-3567091.	-.971	10.	2.	.089	3.211	SI
1422.	521.	3.	2.	1110974.	-.207	.747	2843699.	-1.07	10.	2.	.097	2.56	SI
1470.	570.	3.	2.	-1218809.	-.153	.654	-3567091.	-.971	10.	2.	.089	2.927	SI
1470.	570.	3.	2.	1218809.	-.227	.82	2843699.	-1.07	10.	2.	.097	2.333	SI
1518.	618.	3.	2.	-1301591.	-.163	.698	-3567091.	-.971	10.	2.	.089	2.741	SI
1518.	618.	3.	2.	1301591.	-.243	.876	2843699.	-1.07	10.	2.	.097	2.185	SI
1566.	666.	3.	3.	-1362061.	-.145	.555	-4696316.	-1.06	10.	2.	.095	3.448	SI
1566.	666.	3.	3.	1362061.	-.204	.57	4599379.	-1.35	10.	2.	.119	3.377	SI
1614.	714.	3.	3.	-1401155.	-.149	.571	-4696316.	-1.06	10.	2.	.095	3.352	SI
1614.	714.	3.	3.	1401155.	-.21	.586	4599379.	-1.35	10.	2.	.119	3.283	SI
1663.	763.	3.	3.	-1410414.	-.15	.575	-4696316.	-1.06	10.	2.	.095	3.33	SI
1663.	763.	3.	3.	1410414.	-.211	.59	4599379.	-1.35	10.	2.	.119	3.261	SI
1711.	811.	3.	3.	-1410024.	-.15	.575	-4696316.	-1.06	10.	2.	.095	3.331	SI
1711.	811.	3.	3.	1410024.	-.211	.59	4599379.	-1.35	10.	2.	.119	3.262	SI
1730.	830.	3.	3.	-1409462.	-.15	.575	-4696316.	-1.06	10.	2.	.095	3.332	SI
1730.	830.	3.	3.	1409462.	-.211	.59	4599379.	-1.35	10.	2.	.119	3.263	SI
1750.	850.	3.	3.	-1408901.	-.15	.574	-4696316.	-1.06	10.	2.	.095	3.333	SI
1750.	850.	3.	3.	1408901.	-.211	.59	4599379.	-1.35	10.	2.	.119	3.265	SI
>1750.	0.	3.	3.	-4439785.	-.488	1.814	-4696316.	-1.06	10.	2.	.095	1.058	SI
1750.	0.	3.	3.	4439785.	-.704	1.959	4599379.	-1.35	10.	2.	.119	1.036	SI
1770.	20.	3.	3.	-4439785.	-.488	1.814	-4696316.	-1.06	10.	2.	.095	1.058	SI
1770.	20.	3.	4.	4439785.	-.583	1.835	4614972.	-1.1	10.	2.	.099	1.039	SI
1789.	39.	3.	4.	-4360537.	-.389	1.033	-8173761.	-1.51	10.	2.	.131	1.874	SI
1789.	39.	3.	4.	4360537.	-.572	1.802	4614972.	-1.1	10.	2.	.099	1.058	SI
1837.	87.	3.	3.	-3509317.	-.382	1.433	-4696316.	-1.06	10.	2.	.095	1.338	SI
1837.	87.	3.	3.	3509317.	-.54	1.471	4599379.	-1.35	10.	2.	.119	1.311	SI
1886.	136.	3.	3.	-2680645.	-.289	1.094	-4696316.	-1.06	10.	2.	.095	1.752	SI
1886.	136.	3.	3.	2680645.	-.408	1.123	4599379.	-1.35	10.	2.	.119	1.716	SI
1934.	184.	3.	3.	-1933252.	-.207	.788	-4696316.	-1.06	10.	2.	.095	2.429	SI
1934.	184.	3.	3.	1933252.	-.291	.809	4599379.	-1.35	10.	2.	.119	2.379	SI
1982.	232.	3.	2.	-1268203.	-.159	.68	-3567091.	-.971	10.	2.	.089	2.813	SI
1982.	232.	3.	2.	1268203.	-.237	.853	2843699.	-1.07	10.	2.	.097	2.242	SI
2031.	281.	3.	2.	-771653.	-.096	.414	-3567091.	-.971	10.	2.	.089	4.623	SI
2031.	281.	3.	2.	771653.	-.143	.519	2843699.	-1.07	10.	2.	.097	3.685	SI
2079.	329.	3.	2.	-652092.	-.081	.35	-3567091.	-.971	10.	2.	.089	5.47	SI
2079.	329.	3.	2.	652092.	-.121	.439	2843699.	-1.07	10.	2.	.097	4.361	SI
2127.	377.	3.	6.	-1055976.	-.121	.563	-3570591.	-.862	10.	2.	.079	3.381	SI
2127.	377.	3.	2.	1055976.	-.197	.71	2843699.	-1.07	10.	2.	.097	2.693	SI
2176.	426.	3.	6.	-1474710.	-.169	.786	-3570591.	-.862	10.	2.	.079	2.421	SI
2176.	426.	3.	6.	1474710.	-.218	.509	5622705.	-1.69	10.	2.	.145	3.813	SI
2224.	474.	3.	2.	-1870528.	-.236	1.004	-3567091.	-.971	10.	2.	.089	1.907	SI
2224.	474.	3.	2.	1870528.	-.353	1.259	2843699.	-1.07	10.	2.	.097	1.52	SI
2273.	523.	3.	2.	-2257059.	-.286	1.211	-3567091.	-.971	10.	2.	.089	1.58	SI
2273.	523.	3.	2.	2257059.	-.428	1.52	2843699.	-1.07	10.	2.	.097	1.26	SI
2321.	571.	3.	2.	-2629058.	-.335	1.411	-3567091.	-.971	10.	2.	.089	1.357	SI
2321.	571.	3.	2.	2629058.	-.502	1.771	2843699.	-1.07	10.	2.	.097	1.082	SI
2369.	619.	3.	7.	-2995754.	-.35	1.598	-3570486.	-.867	10.	2.	.08	1.192	SI
2369.	619.	3.	2.	2995754.	-1.11	10.1	2843699.	-1.07	10.	2.	.097	.949	SI
2418.	668.	3.	8.	-3323471.	-.351	1.353	-4698824.	-1.02	10.	2.	.092	1.414	SI
2418.	668.	3.	8.	3323471.	-.482	1.176	5468640.	-1.52	10.	2.	.132	1.645	SI
2466.	716.	3.	8.	-3628643.	-.384	1.478	-4698824.	-1.02	10.	2.	.092	1.295	SI
2466.	716.	3.	8.	3628643.	-.528	1.284	5468640.	-1.52	10.	2.	.132	1.507	SI
2514.	764.	3.	8.	-3854952.	-.409	1.57	-4698824.	-1.02	10.	2.	.092	1.219	SI
2514.	764.	3.	8.	3854952.	-.563	1.365	5468640.	-1.52	10.	2.	.132	1.419	SI
2563.	813.	3.	8.	-3980340.	-.423	1.621	-4698824.	-1.02	10.	2.	.092	1.181	SI
2563.	813.	3.	8.	3980340.	-.582	1.409	5468640.	-1.52	10.	2.	.132	1.374	SI
2611.	861.	3.	8.	-4077729.	-.434	1.661	-4698824.	-1.02	10.	2.	.092	1.152	SI
2611.	861.	3.	8.	4077729.	-.597	1.444	5468640.	-1.52	10.	2.	.132	1.341	SI
2630.	880.	3.	8.	-4086796.	-.435	1.665	-4698824.	-1.02	10.	2.	.092	1.15	SI
2630.	880.	3.	8.	4086796.	-.599	1.447	5468640.	-1.52	10.	2.	.132	1.338	SI
2650.	900.	3.	8.	-4086796.	-.435	1.665	-4698824.	-1.02	10.	2.	.092	1.15	SI
2650.	900.	3.	8.	4086796.	-.599	1.447	5468640.	-1.52	10.	2.	.132	1.338	SI

VERIFICHE A TAGLIO

TAGLIO:

Progressive	Se	Vsd	VRd1	VRd2	Vrd3	Vod	Vwd	Asw	s	Ve	
> 0.	0.	3.	-16820.	11049.	179747.	61923.	26517.	35406.	2.01	15.	SI

0.	0.	3.	16820.	11049.	179747.	61923.	26517.	35406.	2.01	15.	SI
20.	20.	3.	-16628.	11049.	179747.	61923.	26517.	35406.	2.01	15.	SI
20.	20.	3.	16628.	11049.	179747.	61923.	26517.	35406.	2.01	15.	SI
39.	39.	3.	-16437.	11049.	179747.	61923.	26517.	35406.	2.01	15.	SI
39.	39.	3.	16437.	11049.	179747.	61923.	26517.	35406.	2.01	15.	SI
87.	87.	3.	-15963.	13754.	179747.	61923.	26517.	35406.	2.01	15.	SI
87.	87.	3.	15963.	13754.	179747.	61923.	26517.	35406.	2.01	15.	SI
136.	136.	3.	-15067.	12491.	179747.	35406.	26517.	17703.	2.01	30.	SI
136.	136.	3.	15067.	12491.	179747.	35406.	26517.	17703.	2.01	30.	SI
184.	184.	3.	-13717.	12491.	179747.	35406.	26517.	17703.	2.01	30.	SI
184.	184.	3.	13717.	12491.	179747.	35406.	26517.	17703.	2.01	30.	SI
233.	233.	3.	-12331.	12491.	179747.	35406.	26517.	17703.	2.01	30.	SI
233.	233.	3.	12331.	12491.	179747.	35406.	26517.	17703.	2.01	30.	SI
281.	281.	3.	-10750.	12491.	179747.	35406.	26517.	17703.	2.01	30.	SI
281.	281.	3.	10750.	12491.	179747.	35406.	26517.	17703.	2.01	30.	SI
329.	329.	3.	-9168.	12491.	179747.	35406.	26517.	17703.	2.01	30.	SI
329.	329.	3.	9168.	12491.	179747.	35406.	26517.	17703.	2.01	30.	SI
378.	378.	3.	-7749.	12491.	179747.	35406.	26517.	17703.	2.01	30.	SI
378.	378.	3.	7749.	12491.	179747.	35406.	26517.	17703.	2.01	30.	SI
426.	426.	3.	-6363.	12491.	179747.	35406.	26517.	17703.	2.01	30.	SI
426.	426.	3.	6363.	12491.	179747.	35406.	26517.	17703.	2.01	30.	SI
474.	474.	3.	-5178.	12491.	179747.	35406.	26517.	17703.	2.01	30.	SI
474.	474.	3.	5178.	12491.	179747.	35406.	26517.	17703.	2.01	30.	SI
523.	523.	3.	-4193.	12491.	179747.	35406.	26517.	17703.	2.01	30.	SI
523.	523.	3.	4193.	12491.	179747.	35406.	26517.	17703.	2.01	30.	SI
571.	571.	3.	-3276.	12491.	179747.	35406.	26517.	17703.	2.01	30.	SI
571.	571.	3.	3276.	12491.	179747.	35406.	26517.	17703.	2.01	30.	SI
619.	619.	3.	-2679.	12491.	179747.	35406.	26517.	17703.	2.01	30.	SI
619.	619.	3.	2679.	12491.	179747.	35406.	26517.	17703.	2.01	30.	SI
668.	668.	3.	-2083.	12491.	179747.	35406.	26517.	17703.	2.01	30.	SI
668.	668.	3.	2083.	12491.	179747.	35406.	26517.	17703.	2.01	30.	SI
716.	716.	3.	-1616.	12491.	179747.	35406.	26517.	17703.	2.01	30.	SI
716.	716.	3.	1616.	12491.	179747.	35406.	26517.	17703.	2.01	30.	SI
764.	764.	3.	-1174.	12491.	179747.	35406.	26517.	17703.	2.01	30.	SI
764.	764.	3.	1174.	12491.	179747.	35406.	26517.	17703.	2.01	30.	SI
813.	813.	3.	-917.	12491.	179747.	61923.	26517.	35406.	2.01	15.	SI
813.	813.	3.	917.	12491.	179747.	61923.	26517.	35406.	2.01	15.	SI
861.	861.	3.	-832.	13393.	179747.	61923.	26517.	35406.	2.01	15.	SI
861.	861.	3.	832.	13393.	179747.	61923.	26517.	35406.	2.01	15.	SI
881.	881.	3.	-798.	11626.	179747.	61923.	26517.	35406.	2.01	15.	SI
881.	881.	3.	798.	11626.	179747.	61923.	26517.	35406.	2.01	15.	SI
900.	900.	3.	-764.	11626.	179747.	61923.	26517.	35406.	2.01	15.	SI
900.	900.	3.	764.	11626.	179747.	61923.	26517.	35406.	2.01	15.	SI
> 900.	0.	3.	-18477.	11626.	179747.	61923.	26517.	35406.	2.01	15.	SI
900.	0.	3.	18477.	11626.	179747.	61923.	26517.	35406.	2.01	15.	SI
920.	20.	3.	-17893.	11626.	179747.	61923.	26517.	35406.	2.01	15.	SI
920.	20.	3.	17893.	11626.	179747.	61923.	26517.	35406.	2.01	15.	SI
939.	39.	3.	-17309.	11626.	179747.	61923.	26517.	35406.	2.01	15.	SI
939.	39.	3.	17309.	11626.	179747.	61923.	26517.	35406.	2.01	15.	SI
987.	87.	3.	-15869.	11049.	179747.	61923.	26517.	35406.	2.01	15.	SI
987.	87.	3.	15869.	11049.	179747.	61923.	26517.	35406.	2.01	15.	SI
1036.	136.	3.	-14230.	11049.	179747.	35406.	26517.	17703.	2.01	30.	SI
1036.	136.	3.	14230.	11049.	179747.	35406.	26517.	17703.	2.01	30.	SI
1084.	184.	3.	-12462.	12491.	179747.	35406.	26517.	17703.	2.01	30.	SI
1084.	184.	3.	12462.	12491.	179747.	35406.	26517.	17703.	2.01	30.	SI
1132.	232.	3.	-10731.	12491.	179747.	35406.	26517.	17703.	2.01	30.	SI
1132.	232.	3.	10731.	12491.	179747.	35406.	26517.	17703.	2.01	30.	SI
1180.	280.	3.	-9053.	12491.	179747.	35406.	26517.	17703.	2.01	30.	SI
1180.	280.	3.	9053.	12491.	179747.	35406.	26517.	17703.	2.01	30.	SI
1229.	328.	3.	-7445.	11049.	179747.	35406.	26517.	17703.	2.01	30.	SI
1229.	328.	3.	7445.	11049.	179747.	35406.	26517.	17703.	2.01	30.	SI
1277.	377.	3.	-6111.	11049.	179747.	35406.	26517.	17703.	2.01	30.	SI
1277.	377.	3.	6111.	11049.	179747.	35406.	26517.	17703.	2.01	30.	SI
1325.	425.	3.	-4778.	11049.	179747.	35406.	26517.	17703.	2.01	30.	SI
1325.	425.	3.	4778.	11049.	179747.	35406.	26517.	17703.	2.01	30.	SI
1373.	473.	3.	-3877.	12491.	179747.	35406.	26517.	17703.	2.01	30.	SI
1373.	473.	3.	3877.	12491.	179747.	35406.	26517.	17703.	2.01	30.	SI
1422.	521.	3.	-2977.	12491.	179747.	35406.	26517.	17703.	2.01	30.	SI
1422.	521.	3.	2977.	12491.	179747.	35406.	26517.	17703.	2.01	30.	SI
1470.	570.	3.	-2361.	12491.	179747.	35406.	26517.	17703.	2.01	30.	SI
1470.	570.	3.	2361.	12491.	179747.	35406.	26517.	17703.	2.01	30.	SI
1518.	618.	3.	-1818.	12491.	179747.	35406.	26517.	17703.	2.01	30.	SI
1518.	618.	3.	1818.	12491.	179747.	35406.	26517.	17703.	2.01	30.	SI
1566.	666.	3.	-1345.	12491.	179747.	35406.	26517.	17703.	2.01	30.	SI
1566.	666.	3.	1345.	12491.	179747.	35406.	26517.	17703.	2.01	30.	SI

1614.	714.	3.	-919.	12491.	179747.	35406.	26517.	17703.	2.01	30.	SI
1614.	714.	3.	919.	12491.	179747.	35406.	26517.	17703.	2.01	30.	SI
1663.	763.	3.	-705.	12491.	179747.	61923.	26517.	35406.	2.01	15.	SI
1663.	763.	3.	705.	12491.	179747.	61923.	26517.	35406.	2.01	15.	SI
1711.	811.	3.	-821.	11626.	179747.	61923.	26517.	35406.	2.01	15.	SI
1711.	811.	3.	821.	11626.	179747.	61923.	26517.	35406.	2.01	15.	SI
1730.	830.	3.	-869.	11626.	179747.	61923.	26517.	35406.	2.01	15.	SI
1730.	830.	3.	869.	11626.	179747.	61923.	26517.	35406.	2.01	15.	SI
1750.	850.	3.	-916.	11626.	179747.	61923.	26517.	35406.	2.01	15.	SI
1750.	850.	3.	916.	11626.	179747.	61923.	26517.	35406.	2.01	15.	SI
>1750.	0.	3.	-19080.	11626.	179747.	61923.	26517.	35406.	2.01	15.	SI
1750.	0.	3.	19080.	11626.	179747.	61923.	26517.	35406.	2.01	15.	SI
1770.	20.	3.	-18536.	11626.	179747.	61923.	26517.	35406.	2.01	15.	SI
1770.	20.	3.	18536.	11626.	179747.	61923.	26517.	35406.	2.01	15.	SI
1789.	39.	3.	-17992.	11626.	179747.	61923.	26517.	35406.	2.01	15.	SI
1789.	39.	3.	17992.	11626.	179747.	61923.	26517.	35406.	2.01	15.	SI
1837.	87.	3.	-16647.	11049.	179747.	61923.	26517.	35406.	2.01	15.	SI
1837.	87.	3.	16647.	11049.	179747.	61923.	26517.	35406.	2.01	15.	SI
1886.	136.	3.	-15235.	11049.	179747.	35406.	26517.	17703.	2.01	30.	SI
1886.	136.	3.	15235.	11049.	179747.	35406.	26517.	17703.	2.01	30.	SI
1934.	184.	3.	-13751.	12491.	179747.	35406.	26517.	17703.	2.01	30.	SI
1934.	184.	3.	13751.	12491.	179747.	35406.	26517.	17703.	2.01	30.	SI
1982.	232.	3.	-12319.	12491.	179747.	35406.	26517.	17703.	2.01	30.	SI
1982.	232.	3.	12319.	12491.	179747.	35406.	26517.	17703.	2.01	30.	SI
2031.	281.	3.	-11174.	12491.	179747.	35406.	26517.	17703.	2.01	30.	SI
2031.	281.	3.	11174.	12491.	179747.	35406.	26517.	17703.	2.01	30.	SI
2079.	329.	3.	-10028.	11049.	179747.	35406.	26517.	17703.	2.01	30.	SI
2079.	329.	3.	10028.	11049.	179747.	35406.	26517.	17703.	2.01	30.	SI
2127.	377.	3.	-9312.	11049.	179747.	35406.	26517.	17703.	2.01	30.	SI
2127.	377.	3.	9312.	11049.	179747.	35406.	26517.	17703.	2.01	30.	SI
2176.	426.	3.	-8685.	11049.	179747.	35406.	26517.	17703.	2.01	30.	SI
2176.	426.	3.	8685.	11049.	179747.	35406.	26517.	17703.	2.01	30.	SI
2224.	474.	3.	-8254.	11049.	179747.	35406.	26517.	17703.	2.01	30.	SI
2224.	474.	3.	8254.	11049.	179747.	35406.	26517.	17703.	2.01	30.	SI
2273.	523.	3.	-8021.	12491.	179747.	35406.	26517.	17703.	2.01	30.	SI
2273.	523.	3.	8021.	12491.	179747.	35406.	26517.	17703.	2.01	30.	SI
2321.	571.	3.	-7782.	12491.	179747.	35406.	26517.	17703.	2.01	30.	SI
2321.	571.	3.	7782.	12491.	179747.	35406.	26517.	17703.	2.01	30.	SI
2369.	619.	3.	-7517.	12491.	179747.	35406.	26517.	17703.	2.01	30.	SI
2369.	619.	3.	7517.	12491.	179747.	35406.	26517.	17703.	2.01	30.	SI
2418.	668.	3.	-7252.	12491.	179747.	35406.	26517.	17703.	2.01	30.	SI
2418.	668.	3.	7252.	12491.	179747.	35406.	26517.	17703.	2.01	30.	SI
2466.	716.	3.	-6345.	12491.	179747.	35406.	26517.	17703.	2.01	30.	SI
2466.	716.	3.	6345.	12491.	179747.	35406.	26517.	17703.	2.01	30.	SI
2514.	764.	3.	-5320.	13429.	179747.	35406.	26517.	17703.	2.01	30.	SI
2514.	764.	3.	5320.	13429.	179747.	35406.	26517.	17703.	2.01	30.	SI
2563.	813.	3.	-4136.	13429.	179747.	61923.	26517.	35406.	2.01	15.	SI
2563.	813.	3.	4136.	13429.	179747.	61923.	26517.	35406.	2.01	15.	SI
2611.	861.	3.	-2805.	11049.	179747.	61923.	26517.	35406.	2.01	15.	SI
2611.	861.	3.	2805.	11049.	179747.	61923.	26517.	35406.	2.01	15.	SI
2630.	880.	3.	-2266.	11049.	179747.	61923.	26517.	35406.	2.01	15.	SI
2630.	880.	3.	2266.	11049.	179747.	61923.	26517.	35406.	2.01	15.	SI
2650.	900.	3.	-1727.	11049.	179747.	61923.	26517.	35406.	2.01	15.	SI
2650.	900.	3.	1727.	11049.	179747.	61923.	26517.	35406.	2.01	15.	SI

TENSIONI DI ESERCIZIO E FESSURAZIONE - RARE:

Progressive	Se	Ar	Momento	Scls	Sacc	As	hc,ef	Eps	Sr,max	Wk	Ve	
> 0.	0.	3.	1.	-1137847.	-18.7	1247.8	12.57	7.5	.422	16.95	.072	SI
20.	20.	3.	1.	-1176914.	-19.3	1290.7	12.57	7.5	.443	16.95	.075	SI
39.	39.	3.	1.	-1215980.	-20.	1333.5	12.57	7.5	.464	16.95	.079	SI
87.	87.	3.	1.	-1312458.	-21.6	1439.3	12.57	7.5	.516	16.95	.087	SI
136.	136.	3.	1.	-1355934.	-22.3	1487.	12.57	7.5	.539	16.95	.091	SI
184.	184.	3.	1.	-1342537.	-22.	1472.3	12.57	7.5	.532	16.95	.09	SI
233.	233.	3.	1.	-1319892.	-21.7	1447.5	12.57	7.5	.52	16.95	.088	SI
281.	281.	3.	2.	-1246798.	-20.8	1369.1	12.57	7.5	.482	16.95	.082	SI
329.	329.	3.	2.	-1173703.	-19.6	1288.8	12.57	7.5	.442	16.95	.075	SI
378.	378.	3.	2.	-1059323.	-17.7	1163.2	12.57	7.5	.381	16.95	.065	SI
426.	426.	3.	2.	-936335.	-15.6	1028.2	12.57	7.5	.315	16.95	.053	SI
474.	474.	3.	2.	-780005.	-13.	856.5	12.57	7.5	.251	16.95	.042	SI
523.	523.	3.	2.	-590334.	-9.9	648.2	12.57	7.5	.19	16.95	.032	SI
571.	571.	3.	2.	-384049.	-6.4	421.7	12.57	7.5	.123	16.95	.021	SI
619.	619.	3.	2.	-98086.	-1.6	107.7	12.57	7.5	.032	16.95	.005	SI
668.	668.	3.	2.	187876.	-4.7	259.	10.05	7.5	.076	82.62	.063	SI

716.	716.	3.	3.	579421.	-12.9	576.8	14.07	7.5	.169	78.91	.133	SI
764.	764.	3.	3.	990323.	-22.	985.8	14.07	7.5	.289	78.91	.228	SI
813.	813.	3.	3.	1473097.	-32.7	1466.4	14.07	7.5	.429	78.91	.339	SI
861.	861.	3.	3.	2022853.	-44.9	2013.7	14.07	7.5	.676	78.91	.533	SI
881.	881.	3.	3.	2245465.	-49.8	2235.3	14.07	7.5	.784	78.91	.619	SI
900.	900.	3.	3.	2468076.	-54.8	2456.9	14.07	7.5	.892	78.91	.704	SI
> 900.	0.	3.	3.	598886.	-13.3	596.2	14.07	7.5	.174	78.91	.138	SI
920.	20.	3.	4.	489883.	-9.3	481.2	14.07	7.5	.141	81.43	.115	SI
939.	39.	3.	4.	380879.	-7.3	374.1	14.07	7.5	.11	81.43	.089	SI
987.	87.	3.	4.	112343.	-2.1	110.4	14.07	7.5	.032	81.43	.026	SI
1036.	136.	3.	3.	-98044.	-1.6	107.4	12.57	7.5	.031	16.95	.005	SI
1084.	184.	3.	3.	-271077.	-4.4	296.9	12.57	7.5	.087	16.95	.015	SI
1132.	232.	3.	2.	-412924.	-6.9	453.4	12.57	7.5	.133	16.95	.022	SI
1180.	280.	3.	2.	-509128.	-8.5	559.1	12.57	7.5	.164	16.95	.028	SI
1229.	328.	3.	5.	-592132.	-9.1	646.5	12.57	7.5	.189	16.95	.032	SI
1277.	377.	3.	5.	-623299.	-9.6	680.6	12.57	7.5	.199	16.95	.034	SI
1325.	425.	3.	5.	-654466.	-10.1	714.6	12.57	7.5	.209	16.95	.035	SI
1373.	473.	3.	2.	-625351.	-10.4	686.7	12.57	7.5	.201	16.95	.034	SI
1422.	521.	3.	2.	-596236.	-10.	654.7	12.57	7.5	.192	16.95	.032	SI
1470.	570.	3.	2.	-517128.	-8.6	567.8	12.57	7.5	.166	16.95	.028	SI
1518.	618.	3.	2.	-425290.	-7.1	467.	12.57	7.5	.137	16.95	.023	SI
1566.	666.	3.	3.	-290370.	-4.7	318.1	12.57	7.5	.093	16.95	.016	SI
1614.	714.	3.	3.	-126015.	-2.	138.	12.57	7.5	.04	16.95	.007	SI
1663.	763.	3.	3.	73470.	-1.6	73.1	14.07	7.5	.021	78.91	.017	SI
1711.	811.	3.	3.	327644.	-7.3	326.2	14.07	7.5	.095	78.91	.075	SI
1730.	830.	3.	3.	430818.	-9.6	428.9	14.07	7.5	.126	78.91	.099	SI
1750.	850.	3.	3.	533991.	-11.9	531.6	14.07	7.5	.156	78.91	.123	SI
>1750.	0.	3.	3.	2402555.	-53.3	2391.7	14.07	7.5	.86	78.91	.679	SI
1770.	20.	3.	4.	2186872.	-41.7	2148.2	14.07	7.5	.742	81.43	.604	SI
1789.	39.	3.	4.	1971189.	-37.6	1936.3	14.07	7.5	.638	81.43	.52	SI
1837.	87.	3.	4.	1438616.	-27.4	1413.2	14.07	7.5	.414	81.43	.337	SI
1886.	136.	3.	3.	970058.	-21.5	965.7	14.07	7.5	.283	78.91	.223	SI
1934.	184.	3.	3.	570166.	-12.7	567.6	14.07	7.5	.166	78.91	.131	SI
1982.	232.	3.	2.	188820.	-4.7	260.3	10.05	7.5	.076	82.62	.063	SI
2031.	281.	3.	2.	-91404.	-1.5	100.4	12.57	7.5	.029	16.95	.005	SI
2079.	329.	3.	2.	-371627.	-6.2	408.1	12.57	7.5	.119	16.95	.02	SI
2127.	377.	3.	5.	-575521.	-8.9	628.4	12.57	7.5	.184	16.95	.031	SI
2176.	426.	3.	5.	-763501.	-11.8	833.6	12.57	7.5	.244	16.95	.041	SI
2224.	474.	3.	2.	-919479.	-15.4	1009.6	12.57	7.5	.306	16.95	.052	SI
2273.	523.	3.	2.	-1043454.	-17.4	1145.8	12.57	7.5	.373	16.95	.063	SI
2321.	571.	3.	2.	-1159052.	-19.4	1272.7	12.57	7.5	.435	16.95	.074	SI
2369.	619.	3.	2.	-1234467.	-20.6	1355.5	12.57	7.5	.475	16.95	.08	SI
2418.	668.	3.	1.	-1309881.	-21.5	1436.5	12.57	7.5	.514	16.95	.087	SI
2466.	716.	3.	1.	-1335009.	-21.9	1464.1	12.57	7.5	.528	16.95	.089	SI
2514.	764.	3.	1.	-1350915.	-22.2	1481.5	12.57	7.5	.536	16.95	.091	SI
2563.	813.	3.	1.	-1309656.	-21.5	1436.3	12.57	7.5	.514	16.95	.087	SI
2611.	861.	3.	1.	-1215105.	-20.	1332.6	12.57	7.5	.464	16.95	.079	SI
2630.	880.	3.	1.	-1176813.	-19.3	1290.6	12.57	7.5	.443	16.95	.075	SI
2650.	900.	3.	1.	-1138522.	-18.7	1248.6	12.57	7.5	.423	16.95	.072	SI

TENSIONI DI ESERCIZIO E FESSURAZIONE - QUASI PERMANENTI:

Progressive	Se	Ar	Momento	Scls	Sacc	As	hc,ef	Eps	Sr,max	Wk	Ve	
> 0.	0.	3.	1.	-608384.	-10.	667.2	12.57	7.5	.195	16.95	.033	SI
20.	20.	3.	1.	-641701.	-10.5	703.7	12.57	7.5	.206	16.95	.035	SI
39.	39.	3.	1.	-675017.	-11.1	740.3	12.57	7.5	.217	16.95	.037	SI
87.	87.	3.	1.	-757294.	-12.4	830.5	12.57	7.5	.243	16.95	.041	SI
136.	136.	3.	1.	-803232.	-13.2	880.9	12.57	7.5	.258	16.95	.044	SI
184.	184.	3.	1.	-810176.	-13.3	888.5	12.57	7.5	.26	16.95	.044	SI
233.	233.	3.	1.	-810420.	-13.3	888.8	12.57	7.5	.26	16.95	.044	SI
281.	281.	3.	2.	-774111.	-12.9	850.	12.57	7.5	.249	16.95	.042	SI
329.	329.	3.	2.	-737801.	-12.3	810.2	12.57	7.5	.237	16.95	.04	SI
378.	378.	3.	2.	-672098.	-11.2	738.	12.57	7.5	.216	16.95	.037	SI
426.	426.	3.	2.	-600266.	-10.	659.1	12.57	7.5	.193	16.95	.033	SI
474.	474.	3.	2.	-506427.	-8.5	556.1	12.57	7.5	.163	16.95	.028	SI
523.	523.	3.	2.	-390581.	-6.5	428.9	12.57	7.5	.126	16.95	.021	SI
571.	571.	3.	2.	-264279.	-4.4	290.2	12.57	7.5	.085	16.95	.014	SI
619.	619.	3.	2.	-87833.	-1.5	96.4	12.57	7.5	.028	16.95	.005	SI
668.	668.	3.	2.	88613.	-2.2	122.2	10.05	7.5	.036	82.62	.03	SI
716.	716.	3.	3.	330264.	-7.3	328.8	14.07	7.5	.096	78.91	.076	SI
764.	764.	3.	3.	583870.	-13.	581.2	14.07	7.5	.17	78.91	.134	SI
813.	813.	3.	3.	881764.	-19.6	877.8	14.07	7.5	.257	78.91	.203	SI
861.	861.	3.	3.	1220934.	-27.1	1215.4	14.07	7.5	.356	78.91	.281	SI
881.	881.	3.	3.	1358273.	-30.2	1352.1	14.07	7.5	.396	78.91	.312	SI
900.	900.	3.	3.	1495612.	-33.2	1488.8	14.07	7.5	.436	78.91	.344	SI

> 900.	0.	3.	3.	425368.	-9.4	423.4	14.07	7.5	.124	78.91	.098	SI
920.	20.	3.	4.	353731.	-6.7	347.5	14.07	7.5	.102	81.43	.083	SI
939.	39.	3.	4.	282093.	-5.4	277.1	14.07	7.5	.081	81.43	.066	SI
987.	87.	3.	4.	105610.	-2.	103.7	14.07	7.5	.03	81.43	.025	SI
1036.	136.	3.	3.	-33655.	-.5	36.9	12.57	7.5	.011	16.95	.002	SI
1084.	184.	3.	3.	-149012.	-2.4	163.2	12.57	7.5	.048	16.95	.008	SI
1132.	232.	3.	2.	-243867.	-4.1	267.8	12.57	7.5	.078	16.95	.013	SI
1180.	280.	3.	2.	-308715.	-5.2	339.	12.57	7.5	.099	16.95	.017	SI
1229.	328.	3.	5.	-364702.	-5.6	398.2	12.57	7.5	.117	16.95	.02	SI
1277.	377.	3.	5.	-385890.	-5.9	421.3	12.57	7.5	.123	16.95	.021	SI
1325.	425.	3.	5.	-407078.	-6.3	444.5	12.57	7.5	.13	16.95	.022	SI
1373.	473.	3.	2.	-387560.	-6.5	425.6	12.57	7.5	.125	16.95	.021	SI
1422.	521.	3.	2.	-368042.	-6.1	404.1	12.57	7.5	.118	16.95	.02	SI
1470.	570.	3.	2.	-315225.	-5.3	346.1	12.57	7.5	.101	16.95	.017	SI
1518.	618.	3.	2.	-253930.	-4.2	278.8	12.57	7.5	.082	16.95	.014	SI
1566.	666.	3.	3.	-164714.	-2.7	180.4	12.57	7.5	.053	16.95	.009	SI
1614.	714.	3.	3.	-56421.	-.9	61.8	12.57	7.5	.018	16.95	.003	SI
1663.	763.	3.	3.	73970.	-1.6	73.6	14.07	7.5	.022	78.91	.017	SI
1711.	811.	3.	3.	238762.	-5.3	237.7	14.07	7.5	.07	78.91	.055	SI
1730.	830.	3.	3.	305654.	-6.8	304.3	14.07	7.5	.089	78.91	.07	SI
1750.	850.	3.	3.	372546.	-8.3	370.9	14.07	7.5	.109	78.91	.086	SI
>1750.	0.	3.	3.	1442263.	-32.	1435.7	14.07	7.5	.42	78.91	.332	SI
1770.	20.	3.	4.	1310567.	-25.	1287.4	14.07	7.5	.377	81.43	.307	SI
1789.	39.	3.	4.	1178871.	-22.5	1158.	14.07	7.5	.339	81.43	.276	SI
1837.	87.	3.	4.	853682.	-16.3	838.6	14.07	7.5	.245	81.43	.2	SI
1886.	136.	3.	3.	567354.	-12.6	564.8	14.07	7.5	.165	78.91	.13	SI
1934.	184.	3.	3.	322711.	-7.2	321.2	14.07	7.5	.094	78.91	.074	SI
1982.	232.	3.	2.	89361.	-2.2	123.2	10.05	7.5	.036	82.62	.03	SI
2031.	281.	3.	2.	-82408.	-1.4	90.5	12.57	7.5	.026	16.95	.004	SI
2079.	329.	3.	2.	-254178.	-4.2	279.1	12.57	7.5	.082	16.95	.014	SI
2127.	377.	3.	5.	-378527.	-5.8	413.3	12.57	7.5	.121	16.95	.02	SI
2176.	426.	3.	5.	-492989.	-7.6	538.3	12.57	7.5	.158	16.95	.027	SI
2224.	474.	3.	2.	-586535.	-9.8	644.1	12.57	7.5	.189	16.95	.032	SI
2273.	523.	3.	2.	-659165.	-11.	723.8	12.57	7.5	.212	16.95	.036	SI
2321.	571.	3.	2.	-725855.	-12.1	797.	12.57	7.5	.233	16.95	.04	SI
2369.	619.	3.	2.	-764051.	-12.8	839.	12.57	7.5	.246	16.95	.042	SI
2418.	668.	3.	1.	-802247.	-13.2	879.8	12.57	7.5	.258	16.95	.044	SI
2466.	716.	3.	1.	-804025.	-13.2	881.7	12.57	7.5	.258	16.95	.044	SI
2514.	764.	3.	1.	-799124.	-13.1	876.4	12.57	7.5	.256	16.95	.043	SI
2563.	813.	3.	1.	-754990.	-12.4	828.	12.57	7.5	.242	16.95	.041	SI
2611.	861.	3.	1.	-674282.	-11.1	739.5	12.57	7.5	.216	16.95	.037	SI
2630.	880.	3.	1.	-641596.	-10.5	703.6	12.57	7.5	.206	16.95	.035	SI
2650.	900.	3.	1.	-608911.	-10.	667.8	12.57	7.5	.195	16.95	.033	SI

Trave filo 3 e 5

Metodo di verifica : stati limite.

Unità di misura : Kgf; cm; cm²; Kgf/cm; Kgfcm; Kgf/cm²; (ferri: mm; cm²);
deform.*1000.

MATERIALI

CLS : Rck =300. ; fck=249. ; fctk= 18.4; fctm= 26.2; Ec= 311769. ;

gc =1.6 ; fcd=155.6; fbd= 25.8; fctd= 11.5; EpsMax=3.5

ACCIAIO: FeB44k; fk(1%)=4383.3; fyk=4383.3; Ea=2050000. ;

ga =1.15; fyd=3811.5; EpsMax=10.

TENSIONI E FESSURE MASSIME IN ESERCIZIO

GRUPPO : a (poco aggressivo).

CLS : Scls(rara)=149.4; Scls(quasi permanente)=112. ; fbd(esercizio)= 25.8

ACCIAIO: Sacc(rara)=3068.; Coeff.Omogein.= 15

FESSURE: Wk(rara)=*** ; Wk(fre.)=.4 ; Wk(q.p.)=.2 ;

c/cmin= 1 [Circ. 15/10/96 N.252 B.6.2]; kt=.4 [EN 1992-1 7.3.4].

SEZIONI UTILIZZATE

3) A T rovescio: largh.=105; alt.=80; sp.ala=30; sp.an.=35; Acls=4900 .

DESCRIZIONE CAMPATE

Cam.	Descriz.	S.ini	Sez.	S.fin	Incl.	L.assi	L.netta
1	A156	3	3	3	0	900.	875.

2	A157	3	3	3	0	850.	825.
3	A158	3	3	3	0	900.	875.

CASI DI CARICO DA MODELLO 3D

SLU			RARE			QUASI PERMANENTI		
Nome	Descrizione	Sest	Nome	Descrizione	Sest	Nome	Descrizione	Sest
9.	Fondazioni	2.						

VERIFICHE ALLO STATO LIMITE ULTIMO

FLESSIONE:

Progressive	SE	Ar	Msd	Epscl	Epsac	Mrd	Epscl	Epsac	Cam	x/d	Mr/Ms	VE	
> 0.	0.	3.	1.	-1299836.	-.172	.92	-2686467.	-.772	10.	2.	.072	2.067	SI
0.	0.	3.	1.	1299836.	-.273	.64	3939417.	-1.66	10.	2.	.142	3.031	SI
20.	20.	3.	1.	-1299836.	-.172	.92	-2686467.	-.772	10.	2.	.072	2.067	SI
20.	20.	3.	1.	1299836.	-.273	.64	3939417.	-1.66	10.	2.	.142	3.031	SI
39.	39.	3.	1.	-1298481.	-.172	.919	-2686467.	-.772	10.	2.	.072	2.069	SI
39.	39.	3.	1.	1298481.	-.273	.639	3939417.	-1.66	10.	2.	.142	3.034	SI
87.	87.	3.	1.	-1283923.	-.17	.908	-2686467.	-.772	10.	2.	.072	2.092	SI
87.	87.	3.	1.	1283923.	-.269	.632	3939417.	-1.66	10.	2.	.142	3.068	SI
136.	136.	3.	1.	-1261989.	-.167	.893	-2686467.	-.772	10.	2.	.072	2.129	SI
136.	136.	3.	1.	1261989.	-.265	.621	3939417.	-1.66	10.	2.	.142	3.122	SI
184.	184.	3.	1.	-1213469.	-.16	.858	-2686467.	-.772	10.	2.	.072	2.214	SI
184.	184.	3.	1.	1213469.	-.254	.597	3939417.	-1.66	10.	2.	.142	3.246	SI
233.	233.	3.	1.	-1143809.	-.151	.809	-2686467.	-.772	10.	2.	.072	2.349	SI
233.	233.	3.	1.	1143809.	-.239	.563	3939417.	-1.66	10.	2.	.142	3.444	SI
281.	281.	3.	2.	-1065296.	-.146	.755	-2686436.	-.808	10.	2.	.075	2.522	SI
281.	281.	3.	2.	1065296.	-.249	.724	2831239.	-1.32	10.	2.	.116	2.658	SI
329.	329.	3.	2.	-971478.	-.133	.689	-2686436.	-.808	10.	2.	.075	2.765	SI
329.	329.	3.	2.	971478.	-.226	.66	2831239.	-1.32	10.	2.	.116	2.914	SI
378.	378.	3.	2.	-870205.	-.119	.617	-2686436.	-.808	10.	2.	.075	3.087	SI
378.	378.	3.	2.	870205.	-.202	.592	2831239.	-1.32	10.	2.	.116	3.254	SI
426.	426.	3.	2.	-748512.	-.102	.531	-2686436.	-.808	10.	2.	.075	3.589	SI
426.	426.	3.	2.	748512.	-.174	.509	2831239.	-1.32	10.	2.	.116	3.782	SI
474.	474.	3.	2.	-614507.	-.084	.436	-2686436.	-.808	10.	2.	.075	4.372	SI
474.	474.	3.	2.	614507.	-.142	.418	2831239.	-1.32	10.	2.	.116	4.607	SI
523.	523.	3.	2.	-450920.	-.061	.32	-2686436.	-.808	10.	2.	.075	5.958	SI
523.	523.	3.	2.	450920.	-.104	.306	2831239.	-1.32	10.	2.	.116	6.279	SI
571.	571.	3.	2.	-285965.	-.039	.203	-2686436.	-.808	10.	2.	.075	9.394	SI
571.	571.	3.	2.	285965.	-.066	.194	2831239.	-1.32	10.	2.	.116	9.901	SI
619.	619.	3.	2.	-421355.	-.057	.299	-2686436.	-.808	10.	2.	.075	6.376	SI
619.	619.	3.	2.	421355.	-.097	.286	2831239.	-1.32	10.	2.	.116	6.719	SI
668.	668.	3.	2.	-714679.	-.097	.507	-2686436.	-.808	10.	2.	.075	3.759	SI
668.	668.	3.	2.	714679.	-.166	.486	2831239.	-1.32	10.	2.	.116	3.962	SI
716.	716.	3.	1.	-1099366.	-.145	.778	-2686467.	-.772	10.	2.	.072	2.444	SI
716.	716.	3.	1.	1099366.	-.23	.541	3939417.	-1.66	10.	2.	.142	3.583	SI
764.	764.	3.	1.	-1540572.	-.204	1.09	-2686467.	-.772	10.	2.	.072	1.744	SI
764.	764.	3.	1.	1540572.	-.325	.759	3939417.	-1.66	10.	2.	.142	2.557	SI
813.	813.	3.	3.	-2041604.	-.207	.736	-5326714.	-1.15	10.	2.	.103	2.609	SI
813.	813.	3.	3.	2041604.	-.364	.987	3966840.	-1.29	10.	2.	.114	1.943	SI
861.	861.	3.	3.	-2559236.	-.261	.923	-5326714.	-1.15	10.	2.	.103	2.081	SI
861.	861.	3.	3.	2559236.	-.46	1.238	3966840.	-1.29	10.	2.	.114	1.55	SI
881.	881.	3.	1.	-2607421.	-.35	1.846	-2686467.	-.772	10.	2.	.072	1.03	SI
881.	881.	3.	1.	2607421.	-.469	1.261	3966840.	-1.29	10.	2.	.114	1.521	SI
900.	900.	3.	1.	-2607421.	-.35	1.846	-2686467.	-.772	10.	2.	.072	1.03	SI
900.	900.	3.	1.	2607421.	-.562	1.286	3939417.	-1.66	10.	2.	.142	1.511	SI
> 900.	0.	3.	1.	-549696.	-.072	.389	-2686467.	-.772	10.	2.	.072	4.887	SI
900.	0.	3.	1.	549696.	-.114	.27	3939417.	-1.66	10.	2.	.142	7.167	SI
920.	20.	3.	1.	-585652.	-.077	.414	-2686467.	-.772	10.	2.	.072	4.587	SI
920.	20.	3.	1.	585652.	-.121	.288	3939417.	-1.66	10.	2.	.142	6.727	SI
939.	39.	3.	1.	-621608.	-.082	.44	-2686467.	-.772	10.	2.	.072	4.322	SI
939.	39.	3.	1.	621608.	-.129	.306	3939417.	-1.66	10.	2.	.142	6.337	SI
987.	87.	3.	1.	-685443.	-.09	.485	-2686467.	-.772	10.	2.	.072	3.919	SI
987.	87.	3.	1.	685443.	-.142	.337	3939417.	-1.66	10.	2.	.142	5.747	SI
1036.	136.	3.	1.	-723687.	-.095	.512	-2686467.	-.772	10.	2.	.072	3.712	SI
1036.	136.	3.	1.	723687.	-.15	.356	3939417.	-1.66	10.	2.	.142	5.444	SI
1084.	184.	3.	1.	-740488.	-.097	.524	-2686467.	-.772	10.	2.	.072	3.628	SI
1084.	184.	3.	1.	740488.	-.154	.364	3939417.	-1.66	10.	2.	.142	5.32	SI
1132.	232.	3.	2.	-743540.	-.101	.527	-2686436.	-.808	10.	2.	.075	3.613	SI
1132.	232.	3.	2.	743540.	-.172	.505	2831239.	-1.32	10.	2.	.116	3.808	SI
1180.	280.	3.	2.	-737866.	-.101	.523	-2686436.	-.808	10.	2.	.075	3.641	SI
1180.	280.	3.	2.	737866.	-.171	.502	2831239.	-1.32	10.	2.	.116	3.837	SI
1229.	328.	3.	2.	-713896.	-.097	.506	-2686436.	-.808	10.	2.	.075	3.763	SI

1229.	328.	3.	2.	713896.	-.165	.485	2831239.	-1.32	10.	2.	.116	3.966	SI
1277.	377.	3.	4.	-665200.	-.083	.469	-2686103.	-.727	10.	2.	.068	4.038	SI
1277.	377.	3.	4.	665200.	-.123	.233	5573743.	-2.17	10.	2.	.178	8.379	SI
1325.	425.	3.	4.	-578252.	-.072	.408	-2686103.	-.727	10.	2.	.068	4.645	SI
1325.	425.	3.	4.	578252.	-.107	.202	5573743.	-2.17	10.	2.	.178	9.639	SI
1373.	473.	3.	2.	-465769.	-.063	.33	-2686436.	-.808	10.	2.	.075	5.768	SI
1373.	473.	3.	2.	465769.	-.107	.316	2831239.	-1.32	10.	2.	.116	6.079	SI
1422.	521.	3.	2.	-288104.	-.039	.204	-2686436.	-.808	10.	2.	.075	9.325	SI
1422.	521.	3.	2.	288104.	-.066	.196	2831239.	-1.32	10.	2.	.116	9.827	SI
1470.	570.	3.	2.	-395620.	-.054	.28	-2686436.	-.808	10.	2.	.075	6.79	SI
1470.	570.	3.	2.	395620.	-.091	.269	2831239.	-1.32	10.	2.	.116	7.156	SI
1518.	618.	3.	2.	-677264.	-.092	.48	-2686436.	-.808	10.	2.	.075	3.967	SI
1518.	618.	3.	2.	677264.	-.157	.46	2831239.	-1.32	10.	2.	.116	4.18	SI
1566.	666.	3.	1.	-1069291.	-.141	.756	-2686467.	-.772	10.	2.	.072	2.512	SI
1566.	666.	3.	1.	1069291.	-.223	.526	3939417.	-1.66	10.	2.	.142	3.684	SI
1614.	714.	3.	1.	-1522856.	-.202	1.078	-2686467.	-.772	10.	2.	.072	1.764	SI
1614.	714.	3.	1.	1522856.	-.321	.75	3939417.	-1.66	10.	2.	.142	2.587	SI
1663.	763.	3.	1.	-2042774.	-.272	1.446	-2686467.	-.772	10.	2.	.072	1.315	SI
1663.	763.	3.	1.	2042774.	-.435	1.007	3939417.	-1.66	10.	2.	.142	1.928	SI
1711.	811.	3.	1.	-2583460.	-.346	1.829	-2686467.	-.772	10.	2.	.072	1.04	SI
1711.	811.	3.	1.	2583460.	-.557	1.274	3939417.	-1.66	10.	2.	.142	1.525	SI
1730.	830.	3.	1.	-2633914.	-.375	2.154	-2686467.	-.772	10.	2.	.072	1.02	SI
1730.	830.	3.	1.	2633914.	-.568	1.299	3939417.	-1.66	10.	2.	.142	1.496	SI
1750.	850.	3.	1.	-2633914.	-.375	2.154	-2686467.	-.772	10.	2.	.072	1.02	SI
1750.	850.	3.	1.	2633914.	-.568	1.299	3939417.	-1.66	10.	2.	.142	1.496	SI
>1750.	0.	3.	1.	-481630.	-.063	.341	-2686467.	-.772	10.	2.	.072	5.578	SI
1750.	0.	3.	1.	481630.	-.1	.237	3939417.	-1.66	10.	2.	.142	8.179	SI
1770.	20.	3.	1.	-509703.	-.067	.36	-2686467.	-.772	10.	2.	.072	5.271	SI
1770.	20.	3.	1.	509703.	-.105	.251	3939417.	-1.66	10.	2.	.142	7.729	SI
1789.	39.	3.	1.	-537775.	-.07	.38	-2686467.	-.772	10.	2.	.072	4.996	SI
1789.	39.	3.	1.	537775.	-.111	.264	3939417.	-1.66	10.	2.	.142	7.325	SI
1837.	87.	3.	3.	-589332.	-.059	.212	-5326714.	-1.15	10.	2.	.103	9.039	SI
1837.	87.	3.	3.	589332.	-.103	.285	3966840.	-1.29	10.	2.	.114	6.731	SI
1886.	136.	3.	3.	-614824.	-.062	.221	-5326714.	-1.15	10.	2.	.103	8.664	SI
1886.	136.	3.	3.	614824.	-.108	.297	3966840.	-1.29	10.	2.	.114	6.452	SI
1934.	184.	3.	1.	-629245.	-.083	.445	-2686467.	-.772	10.	2.	.072	4.269	SI
1934.	184.	3.	1.	629245.	-.13	.309	3939417.	-1.66	10.	2.	.142	6.261	SI
1982.	232.	3.	2.	-632932.	-.086	.449	-2686436.	-.808	10.	2.	.075	4.244	SI
1982.	232.	3.	2.	632932.	-.146	.43	2831239.	-1.32	10.	2.	.116	4.473	SI
2031.	281.	3.	2.	-628980.	-.086	.446	-2686436.	-.808	10.	2.	.075	4.271	SI
2031.	281.	3.	2.	628980.	-.146	.427	2831239.	-1.32	10.	2.	.116	4.501	SI
2079.	329.	3.	2.	-615023.	-.084	.436	-2686436.	-.808	10.	2.	.075	4.368	SI
2079.	329.	3.	2.	615023.	-.142	.418	2831239.	-1.32	10.	2.	.116	4.603	SI
2127.	377.	3.	2.	-593625.	-.081	.421	-2686436.	-.808	10.	2.	.075	4.525	SI
2127.	377.	3.	2.	593625.	-.137	.403	2831239.	-1.32	10.	2.	.116	4.769	SI
2176.	426.	3.	4.	-551835.	-.069	.389	-2686103.	-.727	10.	2.	.068	4.868	SI
2176.	426.	3.	4.	551835.	-.102	.193	5573743.	-2.17	10.	2.	.178	10.1	SI
2224.	474.	3.	4.	-499846.	-.062	.353	-2686103.	-.727	10.	2.	.068	5.374	SI
2224.	474.	3.	4.	499846.	-.092	.175	5573743.	-2.17	10.	2.	.178	11.15	SI
2273.	523.	3.	2.	-425706.	-.058	.302	-2686436.	-.808	10.	2.	.075	6.311	SI
2273.	523.	3.	2.	425706.	-.098	.289	2831239.	-1.32	10.	2.	.116	6.651	SI
2321.	571.	3.	2.	-335526.	-.046	.238	-2686436.	-.808	10.	2.	.075	8.007	SI
2321.	571.	3.	2.	335526.	-.077	.228	2831239.	-1.32	10.	2.	.116	8.438	SI
2369.	619.	3.	2.	-244157.	-.033	.173	-2686436.	-.808	10.	2.	.075	11.	SI
2369.	619.	3.	2.	244157.	-.056	.166	2831239.	-1.32	10.	2.	.116	11.6	SI
2418.	668.	3.	1.	-215455.	-.028	.152	-2686467.	-.772	10.	2.	.072	12.47	SI
2418.	668.	3.	1.	215455.	-.044	.106	3939417.	-1.66	10.	2.	.142	18.28	SI
2466.	716.	3.	1.	-435360.	-.057	.308	-2686467.	-.772	10.	2.	.072	6.171	SI
2466.	716.	3.	1.	435360.	-.09	.214	3939417.	-1.66	10.	2.	.142	9.049	SI
2514.	764.	3.	1.	-703994.	-.092	.498	-2686467.	-.772	10.	2.	.072	3.816	SI
2514.	764.	3.	1.	703994.	-.146	.346	3939417.	-1.66	10.	2.	.142	5.596	SI
2563.	813.	3.	1.	-1018223.	-.134	.72	-2686467.	-.772	10.	2.	.072	2.638	SI
2563.	813.	3.	1.	1018223.	-.213	.501	3939417.	-1.66	10.	2.	.142	3.869	SI
2611.	861.	3.	1.	-1345100.	-.178	.952	-2686467.	-.772	10.	2.	.072	1.997	SI
2611.	861.	3.	1.	1345100.	-.283	.662	3939417.	-1.66	10.	2.	.142	2.929	SI
2630.	880.	3.	1.	-1375532.	-.182	.973	-2686467.	-.772	10.	2.	.072	1.953	SI
2630.	880.	3.	1.	1375532.	-.289	.677	3939417.	-1.66	10.	2.	.142	2.864	SI
2650.	900.	3.	1.	-1375532.	-.182	.973	-2686467.	-.772	10.	2.	.072	1.953	SI
2650.	900.	3.	1.	1375532.	-.289	.677	3939417.	-1.66	10.	2.	.142	2.864	SI

VERIFICHE A TAGLIO

TAGLIO:

Progressive | Se | Vsd | VRd1 | VRd2 | Vrd3 | Vcd | Vwd | Asw | s | Ve |

>	0.	0.	3.	-698.	7734.	125823.	35406.	18562.	17703.	1.01	15.	SI
	0.	0.	3.	698.	7734.	125823.	35406.	18562.	17703.	1.01	15.	SI
	20.	20.	3.	-756.	7734.	125823.	35406.	18562.	17703.	1.01	15.	SI
	20.	20.	3.	756.	7734.	125823.	35406.	18562.	17703.	1.01	15.	SI
	39.	39.	3.	-815.	7734.	125823.	35406.	18562.	17703.	1.01	15.	SI
	39.	39.	3.	815.	7734.	125823.	35406.	18562.	17703.	1.01	15.	SI
	87.	87.	3.	-959.	9087.	125823.	35406.	18562.	17703.	1.01	15.	SI
	87.	87.	3.	959.	9087.	125823.	35406.	18562.	17703.	1.01	15.	SI
	136.	136.	3.	-1174.	9087.	125823.	25290.	18562.	12645.	1.01	21.	SI
	136.	136.	3.	1174.	9087.	125823.	25290.	18562.	12645.	1.01	21.	SI
	184.	184.	3.	-1463.	9087.	125823.	25290.	18562.	12645.	1.01	21.	SI
	184.	184.	3.	1463.	9087.	125823.	25290.	18562.	12645.	1.01	21.	SI
	233.	233.	3.	-1741.	9087.	125823.	25290.	18562.	12645.	1.01	21.	SI
	233.	233.	3.	1741.	9087.	125823.	25290.	18562.	12645.	1.01	21.	SI
	281.	281.	3.	-1953.	9087.	125823.	25290.	18562.	12645.	1.01	21.	SI
	281.	281.	3.	1953.	9087.	125823.	25290.	18562.	12645.	1.01	21.	SI
	329.	329.	3.	-2165.	9087.	125823.	25290.	18562.	12645.	1.01	21.	SI
	329.	329.	3.	2165.	9087.	125823.	25290.	18562.	12645.	1.01	21.	SI
	378.	378.	3.	-2519.	9087.	125823.	25290.	18562.	12645.	1.01	21.	SI
	378.	378.	3.	2519.	9087.	125823.	25290.	18562.	12645.	1.01	21.	SI
	426.	426.	3.	-2903.	9087.	125823.	25290.	18562.	12645.	1.01	21.	SI
	426.	426.	3.	2903.	9087.	125823.	25290.	18562.	12645.	1.01	21.	SI
	474.	474.	3.	-3434.	9087.	125823.	25290.	18562.	12645.	1.01	21.	SI
	474.	474.	3.	3434.	9087.	125823.	25290.	18562.	12645.	1.01	21.	SI
	523.	523.	3.	-4111.	9087.	125823.	25290.	18562.	12645.	1.01	21.	SI
	523.	523.	3.	4111.	9087.	125823.	25290.	18562.	12645.	1.01	21.	SI
	571.	571.	3.	-4837.	9087.	125823.	25290.	18562.	12645.	1.01	21.	SI
	571.	571.	3.	4837.	9087.	125823.	25290.	18562.	12645.	1.01	21.	SI
	619.	619.	3.	-5799.	9087.	125823.	25290.	18562.	12645.	1.01	21.	SI
	619.	619.	3.	5799.	9087.	125823.	25290.	18562.	12645.	1.01	21.	SI
	668.	668.	3.	-6761.	9087.	125823.	25290.	18562.	12645.	1.01	21.	SI
	668.	668.	3.	6761.	9087.	125823.	25290.	18562.	12645.	1.01	21.	SI
	716.	716.	3.	-7848.	9087.	125823.	25290.	18562.	12645.	1.01	21.	SI
	716.	716.	3.	7848.	9087.	125823.	25290.	18562.	12645.	1.01	21.	SI
	764.	764.	3.	-8959.	7734.	125823.	25290.	18562.	12645.	1.01	21.	SI
	764.	764.	3.	8959.	7734.	125823.	25290.	18562.	12645.	1.01	21.	SI
	813.	813.	3.	-10009.	7734.	125823.	35406.	18562.	17703.	1.01	15.	SI
	813.	813.	3.	10009.	7734.	125823.	35406.	18562.	17703.	1.01	15.	SI
	861.	861.	3.	-11004.	7734.	125823.	35406.	18562.	17703.	1.01	15.	SI
	861.	861.	3.	11004.	7734.	125823.	35406.	18562.	17703.	1.01	15.	SI
	881.	881.	3.	-11406.	7734.	125823.	35406.	18562.	17703.	1.01	15.	SI
	881.	881.	3.	11406.	7734.	125823.	35406.	18562.	17703.	1.01	15.	SI
	900.	900.	3.	-11809.	7734.	125823.	35406.	18562.	17703.	1.01	15.	SI
	900.	900.	3.	11809.	7734.	125823.	35406.	18562.	17703.	1.01	15.	SI
>	900.	0.	3.	-2592.	7734.	125823.	35406.	18562.	17703.	1.01	15.	SI
	900.	0.	3.	2592.	7734.	125823.	35406.	18562.	17703.	1.01	15.	SI
	920.	20.	3.	-2334.	7734.	125823.	35406.	18562.	17703.	1.01	15.	SI
	920.	20.	3.	2334.	7734.	125823.	35406.	18562.	17703.	1.01	15.	SI
	939.	39.	3.	-2076.	9087.	125823.	35406.	18562.	17703.	1.01	15.	SI
	939.	39.	3.	2076.	9087.	125823.	35406.	18562.	17703.	1.01	15.	SI
	987.	87.	3.	-1441.	9087.	125823.	35406.	18562.	17703.	1.01	15.	SI
	987.	87.	3.	1441.	9087.	125823.	35406.	18562.	17703.	1.01	15.	SI
	1036.	136.	3.	-903.	9087.	125823.	25290.	18562.	12645.	1.01	21.	SI
	1036.	136.	3.	903.	9087.	125823.	25290.	18562.	12645.	1.01	21.	SI
	1084.	184.	3.	-429.	9087.	125823.	25290.	18562.	12645.	1.01	21.	SI
	1084.	184.	3.	429.	9087.	125823.	25290.	18562.	12645.	1.01	21.	SI
	1132.	232.	3.	-311.	9087.	125823.	25290.	18562.	12645.	1.01	21.	SI
	1132.	232.	3.	311.	9087.	125823.	25290.	18562.	12645.	1.01	21.	SI
	1180.	280.	3.	-715.	9087.	125823.	25290.	18562.	12645.	1.01	21.	SI
	1180.	280.	3.	715.	9087.	125823.	25290.	18562.	12645.	1.01	21.	SI
	1229.	328.	3.	-1186.	7734.	125823.	25290.	18562.	12645.	1.01	21.	SI
	1229.	328.	3.	1186.	7734.	125823.	25290.	18562.	12645.	1.01	21.	SI
	1277.	377.	3.	-1921.	7734.	125823.	25290.	18562.	12645.	1.01	21.	SI
	1277.	377.	3.	1921.	7734.	125823.	25290.	18562.	12645.	1.01	21.	SI
	1325.	425.	3.	-2655.	7734.	125823.	25290.	18562.	12645.	1.01	21.	SI
	1325.	425.	3.	2655.	7734.	125823.	25290.	18562.	12645.	1.01	21.	SI
	1373.	473.	3.	-3628.	9087.	125823.	25290.	18562.	12645.	1.01	21.	SI
	1373.	473.	3.	3628.	9087.	125823.	25290.	18562.	12645.	1.01	21.	SI
	1422.	521.	3.	-4601.	9087.	125823.	25290.	18562.	12645.	1.01	21.	SI
	1422.	521.	3.	4601.	9087.	125823.	25290.	18562.	12645.	1.01	21.	SI
	1470.	570.	3.	-5724.	9087.	125823.	25290.	18562.	12645.	1.01	21.	SI
	1470.	570.	3.	5724.	9087.	125823.	25290.	18562.	12645.	1.01	21.	SI
	1518.	618.	3.	-6886.	9087.	125823.	25290.	18562.	12645.	1.01	21.	SI
	1518.	618.	3.	6886.	9087.	125823.	25290.	18562.	12645.	1.01	21.	SI
	1566.	666.	3.	-8076.	9087.	125823.	25290.	18562.	12645.	1.01	21.	SI

1566.	666.	3.	8076.	9087.	125823.	25290.	18562.	12645.	1.01	21.	SI
1614.	714.	3.	-9286.	9087.	125823.	25290.	18562.	12645.	1.01	21.	SI
1614.	714.	3.	9286.	9087.	125823.	25290.	18562.	12645.	1.01	21.	SI
1663.	763.	3.	-10423.	9087.	125823.	35406.	18562.	17703.	1.01	15.	SI
1663.	763.	3.	10423.	9087.	125823.	35406.	18562.	17703.	1.01	15.	SI
1711.	811.	3.	-11448.	9087.	125823.	35406.	18562.	17703.	1.01	15.	SI
1711.	811.	3.	11448.	9087.	125823.	35406.	18562.	17703.	1.01	15.	SI
1730.	830.	3.	-11865.	9087.	125823.	35406.	18562.	17703.	1.01	15.	SI
1730.	830.	3.	11865.	9087.	125823.	35406.	18562.	17703.	1.01	15.	SI
1750.	850.	3.	-12281.	9087.	125823.	35406.	18562.	17703.	1.01	15.	SI
1750.	850.	3.	12281.	9087.	125823.	35406.	18562.	17703.	1.01	15.	SI
>1750.	0.	3.	-2226.	9087.	125823.	35406.	18562.	17703.	1.01	15.	SI
1750.	0.	3.	2226.	9087.	125823.	35406.	18562.	17703.	1.01	15.	SI
1770.	20.	3.	-1977.	9087.	125823.	35406.	18562.	17703.	1.01	15.	SI
1770.	20.	3.	1977.	9087.	125823.	35406.	18562.	17703.	1.01	15.	SI
1789.	39.	3.	-1728.	7734.	125823.	35406.	18562.	17703.	1.01	15.	SI
1789.	39.	3.	1728.	7734.	125823.	35406.	18562.	17703.	1.01	15.	SI
1837.	87.	3.	-1114.	7734.	125823.	35406.	18562.	17703.	1.01	15.	SI
1837.	87.	3.	1114.	7734.	125823.	35406.	18562.	17703.	1.01	15.	SI
1886.	136.	3.	-633.	7734.	125823.	25290.	18562.	12645.	1.01	21.	SI
1886.	136.	3.	633.	7734.	125823.	25290.	18562.	12645.	1.01	21.	SI
1934.	184.	3.	-297.	7734.	125823.	25290.	18562.	12645.	1.01	21.	SI
1934.	184.	3.	297.	7734.	125823.	25290.	18562.	12645.	1.01	21.	SI
1982.	232.	3.	-51.	9087.	125823.	25290.	18562.	12645.	1.01	21.	SI
1982.	232.	3.	51.	9087.	125823.	25290.	18562.	12645.	1.01	21.	SI
2031.	281.	3.	-300.	9087.	125823.	25290.	18562.	12645.	1.01	21.	SI
2031.	281.	3.	300.	9087.	125823.	25290.	18562.	12645.	1.01	21.	SI
2079.	329.	3.	-549.	9087.	125823.	25290.	18562.	12645.	1.01	21.	SI
2079.	329.	3.	549.	9087.	125823.	25290.	18562.	12645.	1.01	21.	SI
2127.	377.	3.	-860.	7734.	125823.	25290.	18562.	12645.	1.01	21.	SI
2127.	377.	3.	860.	7734.	125823.	25290.	18562.	12645.	1.01	21.	SI
2176.	426.	3.	-1184.	7734.	125823.	25290.	18562.	12645.	1.01	21.	SI
2176.	426.	3.	1184.	7734.	125823.	25290.	18562.	12645.	1.01	21.	SI
2224.	474.	3.	-1582.	7734.	125823.	25290.	18562.	12645.	1.01	21.	SI
2224.	474.	3.	1582.	7734.	125823.	25290.	18562.	12645.	1.01	21.	SI
2273.	523.	3.	-2055.	7734.	125823.	25290.	18562.	12645.	1.01	21.	SI
2273.	523.	3.	2055.	7734.	125823.	25290.	18562.	12645.	1.01	21.	SI
2321.	571.	3.	-2557.	9087.	125823.	25290.	18562.	12645.	1.01	21.	SI
2321.	571.	3.	2557.	9087.	125823.	25290.	18562.	12645.	1.01	21.	SI
2369.	619.	3.	-3204.	9087.	125823.	25290.	18562.	12645.	1.01	21.	SI
2369.	619.	3.	3204.	9087.	125823.	25290.	18562.	12645.	1.01	21.	SI
2418.	668.	3.	-3850.	9087.	125823.	25290.	18562.	12645.	1.01	21.	SI
2418.	668.	3.	3850.	9087.	125823.	25290.	18562.	12645.	1.01	21.	SI
2466.	716.	3.	-4617.	9087.	125823.	25290.	18562.	12645.	1.01	21.	SI
2466.	716.	3.	4617.	9087.	125823.	25290.	18562.	12645.	1.01	21.	SI
2514.	764.	3.	-5404.	9087.	125823.	25290.	18562.	12645.	1.01	21.	SI
2514.	764.	3.	5404.	9087.	125823.	25290.	18562.	12645.	1.01	21.	SI
2563.	813.	3.	-6218.	9087.	125823.	35406.	18562.	17703.	1.01	15.	SI
2563.	813.	3.	6218.	9087.	125823.	35406.	18562.	17703.	1.01	15.	SI
2611.	861.	3.	-7057.	7734.	125823.	35406.	18562.	17703.	1.01	15.	SI
2611.	861.	3.	7057.	7734.	125823.	35406.	18562.	17703.	1.01	15.	SI
2630.	880.	3.	-7396.	7734.	125823.	35406.	18562.	17703.	1.01	15.	SI
2630.	880.	3.	7396.	7734.	125823.	35406.	18562.	17703.	1.01	15.	SI
2650.	900.	3.	-7736.	7734.	125823.	35406.	18562.	17703.	1.01	15.	SI
2650.	900.	3.	7736.	7734.	125823.	35406.	18562.	17703.	1.01	15.	SI

TENSIONI DI ESERCIZIO E FESSURAZIONE - RARE:

Progressive	Se	Ar	Momento	Scls	Sacc	As	hc,ef	Eps	Sr,max	Wk	Ve	
> 0.	0.	3.	1.	-189367.	-3.3	274.4	9.42	7.5	.08	16.27	.013	SI
20.	20.	3.	1.	-256199.	-4.5	371.3	9.42	7.5	.109	16.27	.018	SI
39.	39.	3.	1.	-323030.	-5.7	468.1	9.42	7.5	.137	16.27	.022	SI
87.	87.	3.	1.	-488076.	-8.6	707.3	9.42	7.5	.207	16.27	.034	SI
136.	136.	3.	1.	-612376.	-10.8	887.5	9.42	7.5	.26	16.27	.042	SI
184.	184.	3.	1.	-692954.	-12.2	1004.2	9.42	7.5	.314	16.27	.051	SI
233.	233.	3.	1.	-764318.	-13.5	1107.6	9.42	7.5	.364	16.27	.059	SI
281.	281.	3.	2.	-785426.	-14.4	1140.4	9.42	7.5	.38	16.27	.062	SI
329.	329.	3.	2.	-806535.	-14.7	1171.1	9.42	7.5	.395	16.27	.064	SI
378.	378.	3.	2.	-780974.	-14.3	1134.	9.42	7.5	.377	16.27	.061	SI
426.	426.	3.	2.	-745683.	-13.6	1082.7	9.42	7.5	.352	16.27	.057	SI
474.	474.	3.	2.	-676141.	-12.4	981.7	9.42	7.5	.303	16.27	.049	SI
523.	523.	3.	2.	-572347.	-10.5	831.	9.42	7.5	.243	16.27	.04	SI
571.	571.	3.	2.	-453193.	-8.3	658.	9.42	7.5	.193	16.27	.031	SI
619.	619.	3.	2.	-260370.	-4.8	378.1	9.42	7.5	.111	16.27	.018	SI

668.	668.	3.	2.	-67548.	-1.2	98.1	9.42	7.5	.029	16.27	.005	SI
716.	716.	3.	1.	219266.	-6.1	221.	14.07	7.5	.065	74.67	.048	SI
764.	764.	3.	1.	523311.	-14.6	527.4	14.07	7.5	.154	74.67	.115	SI
813.	813.	3.	3.	893783.	-21.4	886.3	14.07	7.5	.259	77.4	.201	SI
861.	861.	3.	3.	1326163.	-31.7	1315.	14.07	7.5	.385	77.4	.298	SI
881.	881.	3.	3.	1501245.	-35.9	1488.6	14.07	7.5	.436	77.4	.337	SI
900.	900.	3.	1.	1676327.	-46.7	1689.6	14.07	7.5	.504	74.67	.376	SI
> 900.	0.	3.	1.	1431409.	-39.9	1442.7	14.07	7.5	.422	74.67	.315	SI
920.	20.	3.	1.	1256573.	-35.	1266.5	14.07	7.5	.371	74.67	.277	SI
939.	39.	3.	1.	1081737.	-30.1	1090.3	14.07	7.5	.319	74.67	.238	SI
987.	87.	3.	1.	651019.	-18.1	656.2	14.07	7.5	.192	74.67	.143	SI
1036.	136.	3.	1.	296535.	-8.3	298.9	14.07	7.5	.087	74.67	.065	SI
1084.	184.	3.	1.	-8979.	-.2	13.	9.42	7.5	.004	16.27	.001	SI
1132.	232.	3.	2.	-264498.	-4.8	384.	9.42	7.5	.112	16.27	.018	SI
1180.	280.	3.	2.	-446849.	-8.2	648.8	9.42	7.5	.19	16.27	.031	SI
1229.	328.	3.	2.	-604575.	-11.1	877.8	9.42	7.5	.257	16.27	.042	SI
1277.	377.	3.	4.	-665592.	-11.2	962.2	9.42	7.5	.293	16.27	.048	SI
1325.	425.	3.	4.	-726610.	-12.2	1050.5	9.42	7.5	.336	16.27	.055	SI
1373.	473.	3.	2.	-667751.	-12.2	969.6	9.42	7.5	.297	16.27	.048	SI
1422.	521.	3.	2.	-608892.	-11.1	884.1	9.42	7.5	.259	16.27	.042	SI
1470.	570.	3.	2.	-455219.	-8.3	661.	9.42	7.5	.193	16.27	.031	SI
1518.	618.	3.	2.	-277403.	-5.1	402.8	9.42	7.5	.118	16.27	.019	SI
1566.	666.	3.	1.	-29047.	-.5	42.1	9.42	7.5	.012	16.27	.002	SI
1614.	714.	3.	1.	267505.	-7.5	269.6	14.07	7.5	.079	74.67	.059	SI
1663.	763.	3.	1.	610749.	-17.	615.6	14.07	7.5	.18	74.67	.135	SI
1711.	811.	3.	1.	1026679.	-28.6	1034.8	14.07	7.5	.303	74.67	.226	SI
1730.	830.	3.	1.	1195511.	-33.3	1205.	14.07	7.5	.353	74.67	.263	SI
1750.	850.	3.	1.	1364344.	-38.	1375.1	14.07	7.5	.402	74.67	.301	SI
>1750.	0.	3.	1.	1609176.	-44.8	1621.9	14.07	7.5	.475	74.67	.354	SI
1770.	20.	3.	1.	1441238.	-40.1	1452.6	14.07	7.5	.425	74.67	.317	SI
1789.	39.	3.	1.	1273299.	-35.5	1283.4	14.07	7.5	.376	74.67	.28	SI
1837.	87.	3.	3.	858618.	-20.5	851.4	14.07	7.5	.249	77.4	.193	SI
1886.	136.	3.	3.	502821.	-12.	498.6	14.07	7.5	.146	77.4	.113	SI
1934.	184.	3.	1.	210188.	-5.9	211.8	14.07	7.5	.062	74.67	.046	SI
1982.	232.	3.	2.	-66039.	-1.2	95.9	9.42	7.5	.028	16.27	.005	SI
2031.	281.	3.	2.	-252805.	-4.6	367.1	9.42	7.5	.107	16.27	.017	SI
2079.	329.	3.	2.	-439572.	-8.	638.2	9.42	7.5	.187	16.27	.03	SI
2127.	377.	3.	2.	-556080.	-10.2	807.4	9.42	7.5	.236	16.27	.038	SI
2176.	426.	3.	4.	-657941.	-11.1	951.2	9.42	7.5	.288	16.27	.047	SI
2224.	474.	3.	4.	-726934.	-12.2	1050.9	9.42	7.5	.337	16.27	.055	SI
2273.	523.	3.	2.	-763059.	-14.	1107.9	9.42	7.5	.364	16.27	.059	SI
2321.	571.	3.	2.	-789708.	-14.4	1146.6	9.42	7.5	.383	16.27	.062	SI
2369.	619.	3.	2.	-770905.	-14.1	1119.3	9.42	7.5	.37	16.27	.06	SI
2418.	668.	3.	1.	-752102.	-13.3	1089.9	9.42	7.5	.356	16.27	.058	SI
2466.	716.	3.	1.	-683397.	-12.1	990.4	9.42	7.5	.307	16.27	.05	SI
2514.	764.	3.	1.	-605540.	-10.7	877.5	9.42	7.5	.257	16.27	.042	SI
2563.	813.	3.	1.	-483855.	-8.6	701.2	9.42	7.5	.205	16.27	.033	SI
2611.	861.	3.	1.	-321312.	-5.7	465.6	9.42	7.5	.136	16.27	.022	SI
2630.	880.	3.	1.	-255484.	-4.5	370.2	9.42	7.5	.108	16.27	.018	SI
2650.	900.	3.	1.	-189657.	-3.4	274.9	9.42	7.5	.08	16.27	.013	SI

TENSIONI DI ESERCIZIO E FESSURAZIONE - QUASI PERMANENTI:

Progressive	Se	Ar	Momento	Scls	Sacc	As	hc,ef	Eps	Sr,max	Wk	Ve	
> 0.	0.	3.	1.	-125386.	-2.2	181.7	9.42	7.5	.053	16.27	.009	SI
20.	20.	3.	1.	-176023.	-3.1	255.1	9.42	7.5	.075	16.27	.012	SI
39.	39.	3.	1.	-226660.	-4.	328.5	9.42	7.5	.096	16.27	.016	SI
87.	87.	3.	1.	-351712.	-6.2	509.7	9.42	7.5	.149	16.27	.024	SI
136.	136.	3.	1.	-446000.	-7.9	646.3	9.42	7.5	.189	16.27	.031	SI
184.	184.	3.	1.	-507277.	-9.	735.1	9.42	7.5	.215	16.27	.035	SI
233.	233.	3.	1.	-561599.	-9.9	813.9	9.42	7.5	.238	16.27	.039	SI
281.	281.	3.	2.	-577985.	-10.6	839.2	9.42	7.5	.246	16.27	.04	SI
329.	329.	3.	2.	-594371.	-10.9	863.	9.42	7.5	.253	16.27	.041	SI
378.	378.	3.	2.	-575978.	-10.5	836.3	9.42	7.5	.245	16.27	.04	SI
426.	426.	3.	2.	-550333.	-10.1	799.1	9.42	7.5	.234	16.27	.038	SI
474.	474.	3.	2.	-499531.	-9.1	725.3	9.42	7.5	.212	16.27	.035	SI
523.	523.	3.	2.	-423572.	-7.7	615.	9.42	7.5	.18	16.27	.029	SI
571.	571.	3.	2.	-336421.	-6.2	488.5	9.42	7.5	.143	16.27	.023	SI
619.	619.	3.	2.	-195601.	-3.6	284.	9.42	7.5	.083	16.27	.014	SI
668.	668.	3.	2.	-54780.	-1.	79.5	9.42	7.5	.023	16.27	.004	SI
716.	716.	3.	1.	154314.	-4.3	155.5	14.07	7.5	.046	74.67	.034	SI
764.	764.	3.	1.	375924.	-10.5	378.9	14.07	7.5	.111	74.67	.083	SI
813.	813.	3.	3.	645786.	-15.5	640.4	14.07	7.5	.187	77.4	.145	SI
861.	861.	3.	3.	960617.	-23.	952.5	14.07	7.5	.279	77.4	.216	SI
881.	881.	3.	3.	1088100.	-26.	1078.9	14.07	7.5	.316	77.4	.244	SI

900.	900.	3.	1.	1215584.	-33.9	1225.2	14.07	7.5	.359	74.67	.268	SI
> 900.	0.	3.	1.	1048879.	-29.2	1057.2	14.07	7.5	.309	74.67	.231	SI
920.	20.	3.	1.	921414.	-25.7	928.7	14.07	7.5	.272	74.67	.203	SI
939.	39.	3.	1.	793948.	-22.1	800.2	14.07	7.5	.234	74.67	.175	SI
987.	87.	3.	1.	479931.	-13.4	483.7	14.07	7.5	.142	74.67	.106	SI
1036.	136.	3.	1.	221507.	-6.2	223.3	14.07	7.5	.065	74.67	.049	SI
1084.	184.	3.	1.	-1205.	0.	1.7	9.42	7.5	.001	16.27	0.	SI
1132.	232.	3.	2.	-187458.	-3.4	272.2	9.42	7.5	.08	16.27	.013	SI
1180.	280.	3.	2.	-320351.	-5.9	465.1	9.42	7.5	.136	16.27	.022	SI
1229.	328.	3.	2.	-435317.	-8.	632.1	9.42	7.5	.185	16.27	.03	SI
1277.	377.	3.	4.	-479879.	-8.1	693.8	9.42	7.5	.203	16.27	.033	SI
1325.	425.	3.	4.	-524442.	-8.8	758.2	9.42	7.5	.222	16.27	.036	SI
1373.	473.	3.	2.	-482000.	-8.8	699.9	9.42	7.5	.205	16.27	.033	SI
1422.	521.	3.	2.	-439559.	-8.	638.2	9.42	7.5	.187	16.27	.03	SI
1470.	570.	3.	2.	-328576.	-6.	477.1	9.42	7.5	.14	16.27	.023	SI
1518.	618.	3.	2.	-200139.	-3.7	290.6	9.42	7.5	.085	16.27	.014	SI
1566.	666.	3.	1.	-20928.	-.4	30.3	9.42	7.5	.009	16.27	.001	SI
1614.	714.	3.	1.	192976.	-5.4	194.5	14.07	7.5	.057	74.67	.043	SI
1663.	763.	3.	1.	440350.	-12.3	443.8	14.07	7.5	.13	74.67	.097	SI
1711.	811.	3.	1.	739830.	-20.6	745.7	14.07	7.5	.218	74.67	.163	SI
1730.	830.	3.	1.	861394.	-24.	868.2	14.07	7.5	.254	74.67	.19	SI
1750.	850.	3.	1.	982959.	-27.4	990.7	14.07	7.5	.29	74.67	.217	SI
>1750.	0.	3.	1.	1149585.	-32.	1158.7	14.07	7.5	.339	74.67	.253	SI
1770.	20.	3.	1.	1029125.	-28.7	1037.3	14.07	7.5	.304	74.67	.227	SI
1789.	39.	3.	1.	908666.	-25.3	915.8	14.07	7.5	.268	74.67	.2	SI
1837.	87.	3.	3.	611222.	-14.6	606.1	14.07	7.5	.177	77.4	.137	SI
1886.	136.	3.	3.	355776.	-8.5	352.8	14.07	7.5	.103	77.4	.08	SI
1934.	184.	3.	1.	145379.	-4.	146.5	14.07	7.5	.043	74.67	.032	SI
1982.	232.	3.	2.	-53312.	-1.	77.4	9.42	7.5	.023	16.27	.004	SI
2031.	281.	3.	2.	-188180.	-3.4	273.2	9.42	7.5	.08	16.27	.013	SI
2079.	329.	3.	2.	-323047.	-5.9	469.1	9.42	7.5	.137	16.27	.022	SI
2127.	377.	3.	2.	-407595.	-7.5	591.8	9.42	7.5	.173	16.27	.028	SI
2176.	426.	3.	4.	-481652.	-8.1	696.3	9.42	7.5	.204	16.27	.033	SI
2224.	474.	3.	4.	-531912.	-9.	769.	9.42	7.5	.225	16.27	.037	SI
2273.	523.	3.	2.	-558376.	-10.2	810.7	9.42	7.5	.237	16.27	.039	SI
2321.	571.	3.	2.	-577838.	-10.6	839.	9.42	7.5	.246	16.27	.04	SI
2369.	619.	3.	2.	-563718.	-10.3	818.5	9.42	7.5	.24	16.27	.039	SI
2418.	668.	3.	1.	-549598.	-9.7	796.5	9.42	7.5	.233	16.27	.038	SI
2466.	716.	3.	1.	-497889.	-8.8	721.5	9.42	7.5	.211	16.27	.034	SI
2514.	764.	3.	1.	-439287.	-7.8	636.6	9.42	7.5	.186	16.27	.03	SI
2563.	813.	3.	1.	-347566.	-6.1	503.7	9.42	7.5	.147	16.27	.024	SI
2611.	861.	3.	1.	-224970.	-4.	326.	9.42	7.5	.095	16.27	.016	SI
2630.	880.	3.	1.	-175321.	-3.1	254.1	9.42	7.5	.074	16.27	.012	SI
2650.	900.	3.	1.	-125671.	-2.2	182.1	9.42	7.5	.053	16.27	.009	SI

Trave filo A e D

Metodo di verifica : stati limite.

Unità di misura : Kgf; cm; cm2; Kgf/cm; Kgf/cm; Kgf/cm2; (ferri: mm; cm2);
deform.*1000.

MATERIALI

CLS : Rck =300. ; fck=249. ; fctk= 18.4; fctm= 26.2; Ec= 311769. ;
gc =1.6 ; fcd=155.6; fbd= 25.8; fctd= 11.5; EpsMax=3.5

ACCIAIO: FeB44k; fk(1%)=4383.3; fyk=4383.3; Ea=2050000. ;
ga =1.15; fyd=3811.5; EpsMax=10.

TENSIONI E FESSURE MASSIME IN ESERCIZIO

GRUPPO : a (poco aggressivo).

CLS : Scls(rara)=149.4; Scls(quasi permanente)=112. ; fbd(esercizio)= 25.8

ACCIAIO: Sacc(rara)=3068.; Coeff.Omogein.= 15

FESSURE: Wk(rara)=*** ; Wk(fre.)=.4 ; Wk(q.p.)=.2 ;
c/cmin= 1 [Circ. 15/10/96 N.252 B.6.2]; kt=.4 [EN 1992-1 7.3.4].

SEZIONI UTILIZZATE

3) A T rovescio: largh.=100; alt.=80; sp.ala=30; sp.an.=50; Acls=5500 .

DESCRIZIONE CAMPATE

Cam. | Descriz. | S.ini | Sez. | S.fin | Incl. | L.assi | L.netta |

1	A135	3	3	3	0	395.	357.
2	A136	3	3	3	0	395.	345.
3	A137	3	3	3	0	395.	345.
4	A138	3	3	3	0	395.	345.
5	A139	3	3	3	0	395.	345.
6	A140	3	3	3	0	395.	357.

CASI DI CARICO DA MODELLO 3D

SLU			RARE			QUASI PERMANENTI		
Nome	Descrizione	Sest	Nome	Descrizione	Sest	Nome	Descrizione	Sest
9.	Fondazioni	2.						

VERIFICHE ALLO STATO LIMITE ULTIMO

FLESSIONE:

Progressive	SE	Ar	Msd	Epscl	Epsac	Mrd	Epscl	Epsac	Cam	x/d	Mr/Ms	VE		
>	0.	0.	3.	1.	-1512450.	-.213	1.074	-2684978.	-.825	10.	2.	.076	1.775	SI
	0.	0.	3.	1.	1512450.	-.298	1.022	2840229.	-1.15	10.	2.	.103	1.878	SI
	20.	20.	3.	1.	-1512450.	-.213	1.074	-2684978.	-.825	10.	2.	.076	1.775	SI
	20.	20.	3.	1.	1512450.	-.298	1.022	2840229.	-1.15	10.	2.	.103	1.878	SI
	39.	39.	3.	1.	-1508844.	-.213	1.071	-2684978.	-.825	10.	2.	.076	1.779	SI
	39.	39.	3.	1.	1508844.	-.298	1.02	2840229.	-1.15	10.	2.	.103	1.882	SI
	84.	84.	3.	1.	-1458367.	-.206	1.035	-2684978.	-.825	10.	2.	.076	1.841	SI
	84.	84.	3.	1.	1458367.	-.287	.986	2840229.	-1.15	10.	2.	.103	1.948	SI
	130.	130.	3.	1.	-1348371.	-.19	.957	-2684978.	-.825	10.	2.	.076	1.991	SI
	130.	130.	3.	1.	1348371.	-.265	.911	2840229.	-1.15	10.	2.	.103	2.106	SI
	175.	175.	3.	1.	-1186890.	-.167	.842	-2684978.	-.825	10.	2.	.076	2.262	SI
	175.	175.	3.	1.	1186890.	-.233	.802	2840229.	-1.15	10.	2.	.103	2.393	SI
	220.	220.	3.	1.	-990411.	-.139	.703	-2684978.	-.825	10.	2.	.076	2.711	SI
	220.	220.	3.	1.	990411.	-.194	.669	2840229.	-1.15	10.	2.	.103	2.868	SI
	265.	265.	3.	1.	-773341.	-.108	.549	-2684978.	-.825	10.	2.	.076	3.472	SI
	265.	265.	3.	1.	773341.	-.151	.522	2840229.	-1.15	10.	2.	.103	3.673	SI
	311.	311.	3.	1.	-548385.	-.076	.389	-2684978.	-.825	10.	2.	.076	4.896	SI
	311.	311.	3.	1.	548385.	-.106	.37	2840229.	-1.15	10.	2.	.103	5.179	SI
	356.	356.	3.	1.	-327420.	-.046	.232	-2684978.	-.825	10.	2.	.076	8.2	SI
	356.	356.	3.	1.	327420.	-.063	.221	2840229.	-1.15	10.	2.	.103	8.675	SI
	375.	375.	3.	1.	-236367.	-.033	.168	-2684978.	-.825	10.	2.	.076	11.36	SI
	375.	375.	3.	1.	236367.	-.046	.16	2840229.	-1.15	10.	2.	.103	12.02	SI
	395.	395.	3.	1.	-147731.	-.02	.105	-2684978.	-.825	10.	2.	.076	18.18	SI
	395.	395.	3.	1.	147731.	-.028	.1	2840229.	-1.15	10.	2.	.103	19.23	SI
>	395.	0.	3.	1.	-2626671.	-.402	2.182	-2684978.	-.825	10.	2.	.076	1.022	SI
	395.	0.	3.	1.	2626671.	-.529	1.778	2840229.	-1.15	10.	2.	.103	1.081	SI
	415.	20.	3.	1.	-2626671.	-.402	2.182	-2684978.	-.825	10.	2.	.076	1.022	SI
	415.	20.	3.	1.	2626671.	-.529	1.778	2840229.	-1.15	10.	2.	.103	1.081	SI
	434.	39.	3.	1.	-2565539.	-.367	1.823	-2684978.	-.825	10.	2.	.076	1.047	SI
	434.	39.	3.	1.	2565539.	-.516	1.737	2840229.	-1.15	10.	2.	.103	1.107	SI
	479.	84.	3.	1.	-1958515.	-.278	1.391	-2684978.	-.825	10.	2.	.076	1.371	SI
	479.	84.	3.	1.	1958515.	-.389	1.325	2840229.	-1.15	10.	2.	.103	1.45	SI
	525.	130.	3.	1.	-1385795.	-.195	.984	-2684978.	-.825	10.	2.	.076	1.937	SI
	525.	130.	3.	1.	1385795.	-.273	.937	2840229.	-1.15	10.	2.	.103	2.05	SI
	570.	175.	3.	1.	-853724.	-.119	.606	-2684978.	-.825	10.	2.	.076	3.145	SI
	570.	175.	3.	1.	853724.	-.166	.577	2840229.	-1.15	10.	2.	.103	3.327	SI
	615.	220.	3.	1.	-416171.	-.058	.295	-2684978.	-.825	10.	2.	.076	6.452	SI
	615.	220.	3.	1.	416171.	-.081	.281	2840229.	-1.15	10.	2.	.103	6.825	SI
	660.	265.	3.	1.	-710919.	-.099	.504	-2684978.	-.825	10.	2.	.076	3.777	SI
	660.	265.	3.	1.	710919.	-.138	.48	2840229.	-1.15	10.	2.	.103	3.995	SI
	706.	311.	3.	1.	-1074004.	-.151	.762	-2684978.	-.825	10.	2.	.076	2.5	SI
	706.	311.	3.	1.	1074004.	-.21	.726	2840229.	-1.15	10.	2.	.103	2.645	SI
	751.	356.	3.	1.	-1408224.	-.198	1.	-2684978.	-.825	10.	2.	.076	1.907	SI
	751.	356.	3.	1.	1408224.	-.277	.952	2840229.	-1.15	10.	2.	.103	2.017	SI
	770.	375.	3.	1.	-1440824.	-.203	1.023	-2684978.	-.825	10.	2.	.076	1.864	SI
	770.	375.	3.	1.	1440824.	-.284	.974	2840229.	-1.15	10.	2.	.103	1.971	SI
	790.	395.	3.	1.	-1440824.	-.203	1.023	-2684978.	-.825	10.	2.	.076	1.864	SI
	790.	395.	3.	1.	1440824.	-.284	.974	2840229.	-1.15	10.	2.	.103	1.971	SI
>	790.	0.	3.	1.	-1319238.	-.186	.936	-2684978.	-.825	10.	2.	.076	2.035	SI
	790.	0.	3.	1.	1319238.	-.259	.892	2840229.	-1.15	10.	2.	.103	2.153	SI
	810.	20.	3.	1.	-1319238.	-.186	.936	-2684978.	-.825	10.	2.	.076	2.035	SI
	810.	20.	3.	1.	1319238.	-.259	.892	2840229.	-1.15	10.	2.	.103	2.153	SI
	829.	39.	3.	1.	-1280217.	-.18	.909	-2684978.	-.825	10.	2.	.076	2.097	SI
	829.	39.	3.	1.	1280217.	-.251	.865	2840229.	-1.15	10.	2.	.103	2.219	SI
	874.	84.	3.	1.	-895313.	-.125	.635	-2684978.	-.825	10.	2.	.076	2.999	SI
	874.	84.	3.	1.	895313.	-.175	.605	2840229.	-1.15	10.	2.	.103	3.172	SI
	920.	130.	3.	1.	-543482.	-.076	.386	-2684978.	-.825	10.	2.	.076	4.94	SI

920.	130.	3.	1.	543482.	-.105	.367	2840229.	-1.15	10.	2.	.103	5.226	SI
965.	175.	3.	1.	-260669.	-.036	.185	-2684978.	-.825	10.	2.	.076	10.3	SI
965.	175.	3.	1.	260669.	-.05	.176	2840229.	-1.15	10.	2.	.103	10.9	SI
1010.	220.	3.	1.	-399863.	-.056	.284	-2684978.	-.825	10.	2.	.076	6.715	SI
1010.	220.	3.	1.	399863.	-.077	.27	2840229.	-1.15	10.	2.	.103	7.103	SI
1055.	265.	3.	1.	-585392.	-.082	.415	-2684978.	-.825	10.	2.	.076	4.587	SI
1055.	265.	3.	1.	585392.	-.114	.395	2840229.	-1.15	10.	2.	.103	4.852	SI
1101.	311.	3.	1.	-735882.	-.103	.522	-2684978.	-.825	10.	2.	.076	3.649	SI
1101.	311.	3.	1.	735882.	-.143	.497	2840229.	-1.15	10.	2.	.103	3.86	SI
1146.	356.	3.	1.	-854840.	-.12	.606	-2684978.	-.825	10.	2.	.076	3.141	SI
1146.	356.	3.	1.	854840.	-.167	.577	2840229.	-1.15	10.	2.	.103	3.323	SI
1165.	375.	3.	1.	-865962.	-.121	.614	-2684978.	-.825	10.	2.	.076	3.101	SI
1165.	375.	3.	1.	865962.	-.169	.585	2840229.	-1.15	10.	2.	.103	3.28	SI
1185.	395.	3.	1.	-865962.	-.121	.614	-2684978.	-.825	10.	2.	.076	3.101	SI
1185.	395.	3.	1.	865962.	-.169	.585	2840229.	-1.15	10.	2.	.103	3.28	SI
>1185.	0.	3.	1.	-1864038.	-.264	1.324	-2684978.	-.825	10.	2.	.076	1.44	SI
1185.	0.	3.	1.	1864038.	-.37	1.261	2840229.	-1.15	10.	2.	.103	1.524	SI
1205.	20.	3.	1.	-1864038.	-.264	1.324	-2684978.	-.825	10.	2.	.076	1.44	SI
1205.	20.	3.	1.	1864038.	-.37	1.261	2840229.	-1.15	10.	2.	.103	1.524	SI
1224.	39.	3.	1.	-1812137.	-.257	1.287	-2684978.	-.825	10.	2.	.076	1.482	SI
1224.	39.	3.	1.	1812137.	-.359	1.225	2840229.	-1.15	10.	2.	.103	1.567	SI
1269.	84.	3.	1.	-1298460.	-.183	.922	-2684978.	-.825	10.	2.	.076	2.068	SI
1269.	84.	3.	1.	1298460.	-.255	.878	2840229.	-1.15	10.	2.	.103	2.187	SI
1315.	130.	3.	1.	-820806.	-.115	.582	-2684978.	-.825	10.	2.	.076	3.271	SI
1315.	130.	3.	1.	820806.	-.16	.554	2840229.	-1.15	10.	2.	.103	3.46	SI
1360.	175.	3.	1.	-414866.	-.058	.294	-2684978.	-.825	10.	2.	.076	6.472	SI
1360.	175.	3.	1.	414866.	-.08	.28	2840229.	-1.15	10.	2.	.103	6.846	SI
1405.	220.	3.	1.	-564413.	-.079	.4	-2684978.	-.825	10.	2.	.076	4.757	SI
1405.	220.	3.	1.	564413.	-.109	.381	2840229.	-1.15	10.	2.	.103	5.032	SI
1450.	265.	3.	1.	-883475.	-.124	.627	-2684978.	-.825	10.	2.	.076	3.039	SI
1450.	265.	3.	1.	883475.	-.172	.597	2840229.	-1.15	10.	2.	.103	3.215	SI
1496.	311.	3.	1.	-1174956.	-.165	.834	-2684978.	-.825	10.	2.	.076	2.285	SI
1496.	311.	3.	1.	1174956.	-.23	.794	2840229.	-1.15	10.	2.	.103	2.417	SI
1541.	356.	3.	1.	-1442584.	-.203	1.024	-2684978.	-.825	10.	2.	.076	1.861	SI
1541.	356.	3.	1.	1442584.	-.284	.975	2840229.	-1.15	10.	2.	.103	1.969	SI
1560.	375.	3.	1.	-1468671.	-.207	1.042	-2684978.	-.825	10.	2.	.076	1.828	SI
1560.	375.	3.	1.	1468671.	-.289	.993	2840229.	-1.15	10.	2.	.103	1.934	SI
1580.	395.	3.	1.	-1468671.	-.207	1.042	-2684978.	-.825	10.	2.	.076	1.828	SI
1580.	395.	3.	1.	1468671.	-.289	.993	2840229.	-1.15	10.	2.	.103	1.934	SI
>1580.	0.	3.	1.	-1282513.	-.18	.91	-2684978.	-.825	10.	2.	.076	2.094	SI
1580.	0.	3.	1.	1282513.	-.252	.867	2840229.	-1.15	10.	2.	.103	2.215	SI
1600.	20.	3.	1.	-1282513.	-.18	.91	-2684978.	-.825	10.	2.	.076	2.094	SI
1600.	20.	3.	1.	1282513.	-.252	.867	2840229.	-1.15	10.	2.	.103	2.215	SI
1619.	39.	3.	1.	-1248083.	-.176	.886	-2684978.	-.825	10.	2.	.076	2.151	SI
1619.	39.	3.	1.	1248083.	-.245	.843	2840229.	-1.15	10.	2.	.103	2.276	SI
1664.	84.	3.	1.	-908402.	-.127	.645	-2684978.	-.825	10.	2.	.076	2.956	SI
1664.	84.	3.	1.	908402.	-.177	.614	2840229.	-1.15	10.	2.	.103	3.127	SI
1710.	130.	3.	1.	-597732.	-.083	.424	-2684978.	-.825	10.	2.	.076	4.492	SI
1710.	130.	3.	1.	597732.	-.116	.404	2840229.	-1.15	10.	2.	.103	4.752	SI
1755.	175.	3.	1.	-320583.	-.045	.227	-2684978.	-.825	10.	2.	.076	8.375	SI
1755.	175.	3.	1.	320583.	-.062	.216	2840229.	-1.15	10.	2.	.103	8.86	SI
1800.	220.	3.	1.	-235340.	-.033	.167	-2684978.	-.825	10.	2.	.076	11.41	SI
1800.	220.	3.	1.	235340.	-.045	.159	2840229.	-1.15	10.	2.	.103	12.07	SI
1845.	265.	3.	1.	-395303.	-.055	.28	-2684978.	-.825	10.	2.	.076	6.792	SI
1845.	265.	3.	1.	395303.	-.076	.267	2840229.	-1.15	10.	2.	.103	7.185	SI
1891.	311.	3.	1.	-527264.	-.073	.374	-2684978.	-.825	10.	2.	.076	5.092	SI
1891.	311.	3.	1.	527264.	-.102	.356	2840229.	-1.15	10.	2.	.103	5.387	SI
1936.	356.	3.	1.	-632258.	-.088	.449	-2684978.	-.825	10.	2.	.076	4.247	SI
1936.	356.	3.	1.	632258.	-.123	.427	2840229.	-1.15	10.	2.	.103	4.492	SI
1955.	375.	3.	1.	-642097.	-.09	.455	-2684978.	-.825	10.	2.	.076	4.182	SI
1955.	375.	3.	1.	642097.	-.125	.434	2840229.	-1.15	10.	2.	.103	4.423	SI
1975.	395.	3.	1.	-642097.	-.09	.455	-2684978.	-.825	10.	2.	.076	4.182	SI
1975.	395.	3.	1.	642097.	-.125	.434	2840229.	-1.15	10.	2.	.103	4.423	SI
>1975.	0.	3.	1.	-2150623.	-.306	1.527	-2684978.	-.825	10.	2.	.076	1.248	SI
1975.	0.	3.	1.	2150623.	-.429	1.455	2840229.	-1.15	10.	2.	.103	1.321	SI
1995.	20.	3.	1.	-2150623.	-.306	1.527	-2684978.	-.825	10.	2.	.076	1.248	SI
1995.	20.	3.	1.	2150623.	-.429	1.455	2840229.	-1.15	10.	2.	.103	1.321	SI
2014.	39.	3.	1.	-2099260.	-.298	1.491	-2684978.	-.825	10.	2.	.076	1.279	SI
2014.	39.	3.	1.	2099260.	-.419	1.42	2840229.	-1.15	10.	2.	.103	1.353	SI
2059.	84.	3.	1.	-1589189.	-.224	1.128	-2684978.	-.825	10.	2.	.076	1.69	SI
2059.	84.	3.	1.	1589189.	-.314	1.074	2840229.	-1.15	10.	2.	.103	1.787	SI
2105.	130.	3.	1.	-1106606.	-.155	.785	-2684978.	-.825	10.	2.	.076	2.426	SI
2105.	130.	3.	1.	1106606.	-.217	.748	2840229.	-1.15	10.	2.	.103	2.567	SI
2150.	175.	3.	1.	-651804.	-.091	.462	-2684978.	-.825	10.	2.	.076	4.119	SI
2150.	175.	3.	1.	651804.	-.127	.44	2840229.	-1.15	10.	2.	.103	4.357	SI

2195.	220.	3.	1.	-441724.	-.062	.313	-2684978.	-.825	10.	2.	.076	6.078	SI
2195.	220.	3.	1.	441724.	-.086	.298	2840229.	-1.15	10.	2.	.103	6.43	SI
2240.	265.	3.	1.	-822588.	-.115	.584	-2684978.	-.825	10.	2.	.076	3.264	SI
2240.	265.	3.	1.	822588.	-.16	.556	2840229.	-1.15	10.	2.	.103	3.453	SI
2286.	311.	3.	1.	-1231858.	-.173	.874	-2684978.	-.825	10.	2.	.076	2.18	SI
2286.	311.	3.	1.	1231858.	-.242	.832	2840229.	-1.15	10.	2.	.103	2.306	SI
2331.	356.	3.	1.	-1646799.	-.233	1.169	-2684978.	-.825	10.	2.	.076	1.63	SI
2331.	356.	3.	1.	1646799.	-.326	1.113	2840229.	-1.15	10.	2.	.103	1.725	SI
2350.	375.	3.	1.	-1688218.	-.239	1.199	-2684978.	-.825	10.	2.	.076	1.59	SI
2350.	375.	3.	1.	1688218.	-.334	1.142	2840229.	-1.15	10.	2.	.103	1.682	SI
2370.	395.	3.	1.	-1688218.	-.239	1.199	-2684978.	-.825	10.	2.	.076	1.59	SI
2370.	395.	3.	1.	1688218.	-.334	1.142	2840229.	-1.15	10.	2.	.103	1.682	SI

VERIFICHE A TAGLIO

TAGLIO:

Progressive	Se	Vsd	VRd1	VRd2	Vrd3	Vcd	Vwd	Asw	s	Ve	
> 0.	0.	3.	-259.	11049.	179747.	61923.	26517.	35406.	2.01	15.	SI
0.	0.	3.	259.	11049.	179747.	61923.	26517.	35406.	2.01	15.	SI
20.	20.	3.	-855.	11049.	179747.	61923.	26517.	35406.	2.01	15.	SI
20.	20.	3.	855.	11049.	179747.	61923.	26517.	35406.	2.01	15.	SI
39.	39.	3.	-1450.	11049.	179747.	61923.	26517.	35406.	2.01	15.	SI
39.	39.	3.	1450.	11049.	179747.	61923.	26517.	35406.	2.01	15.	SI
84.	84.	3.	-2800.	12401.	179747.	61923.	26517.	35406.	2.01	15.	SI
84.	84.	3.	2800.	12401.	179747.	61923.	26517.	35406.	2.01	15.	SI
130.	130.	3.	-3846.	12401.	179747.	35406.	26517.	17703.	2.01	30.	SI
130.	130.	3.	3846.	12401.	179747.	35406.	26517.	17703.	2.01	30.	SI
175.	175.	3.	-4533.	12401.	179747.	35406.	26517.	17703.	2.01	30.	SI
175.	175.	3.	4533.	12401.	179747.	35406.	26517.	17703.	2.01	30.	SI
220.	220.	3.	-4909.	12401.	179747.	35406.	26517.	17703.	2.01	30.	SI
220.	220.	3.	4909.	12401.	179747.	35406.	26517.	17703.	2.01	30.	SI
265.	265.	3.	-5008.	12401.	179747.	35406.	26517.	17703.	2.01	30.	SI
265.	265.	3.	5008.	12401.	179747.	35406.	26517.	17703.	2.01	30.	SI
311.	311.	3.	-4860.	12401.	179747.	61923.	26517.	35406.	2.01	15.	SI
311.	311.	3.	4860.	12401.	179747.	61923.	26517.	35406.	2.01	15.	SI
356.	356.	3.	-4482.	12401.	179747.	61923.	26517.	35406.	2.01	15.	SI
356.	356.	3.	4482.	12401.	179747.	61923.	26517.	35406.	2.01	15.	SI
375.	375.	3.	-4238.	12401.	179747.	61923.	26517.	35406.	2.01	15.	SI
375.	375.	3.	4238.	12401.	179747.	61923.	26517.	35406.	2.01	15.	SI
395.	395.	3.	-3995.	12401.	179747.	61923.	26517.	35406.	2.01	15.	SI
395.	395.	3.	3995.	12401.	179747.	61923.	26517.	35406.	2.01	15.	SI
> 395.	0.	3.	-13994.	12401.	179747.	61923.	26517.	35406.	2.01	15.	SI
395.	0.	3.	13994.	12401.	179747.	61923.	26517.	35406.	2.01	15.	SI
415.	20.	3.	-13657.	12401.	179747.	61923.	26517.	35406.	2.01	15.	SI
415.	20.	3.	13657.	12401.	179747.	61923.	26517.	35406.	2.01	15.	SI
434.	39.	3.	-13320.	12401.	179747.	61923.	26517.	35406.	2.01	15.	SI
434.	39.	3.	13320.	12401.	179747.	61923.	26517.	35406.	2.01	15.	SI
479.	84.	3.	-12447.	12401.	179747.	61923.	26517.	35406.	2.01	15.	SI
479.	84.	3.	12447.	12401.	179747.	61923.	26517.	35406.	2.01	15.	SI
525.	130.	3.	-11528.	12401.	179747.	35406.	26517.	17703.	2.01	30.	SI
525.	130.	3.	11528.	12401.	179747.	35406.	26517.	17703.	2.01	30.	SI
570.	175.	3.	-10618.	12401.	179747.	35406.	26517.	17703.	2.01	30.	SI
570.	175.	3.	10618.	12401.	179747.	35406.	26517.	17703.	2.01	30.	SI
615.	220.	3.	-9754.	12401.	179747.	35406.	26517.	17703.	2.01	30.	SI
615.	220.	3.	9754.	12401.	179747.	35406.	26517.	17703.	2.01	30.	SI
660.	265.	3.	-8950.	12401.	179747.	35406.	26517.	17703.	2.01	30.	SI
660.	265.	3.	8950.	12401.	179747.	35406.	26517.	17703.	2.01	30.	SI
706.	311.	3.	-8199.	12401.	179747.	61923.	26517.	35406.	2.01	15.	SI
706.	311.	3.	8199.	12401.	179747.	61923.	26517.	35406.	2.01	15.	SI
751.	356.	3.	-7475.	12401.	179747.	61923.	26517.	35406.	2.01	15.	SI
751.	356.	3.	7475.	12401.	179747.	61923.	26517.	35406.	2.01	15.	SI
770.	375.	3.	-7157.	12401.	179747.	61923.	26517.	35406.	2.01	15.	SI
770.	375.	3.	7157.	12401.	179747.	61923.	26517.	35406.	2.01	15.	SI
790.	395.	3.	-6839.	12401.	179747.	61923.	26517.	35406.	2.01	15.	SI
790.	395.	3.	6839.	12401.	179747.	61923.	26517.	35406.	2.01	15.	SI
> 790.	0.	3.	-9104.	12401.	179747.	61923.	26517.	35406.	2.01	15.	SI
790.	0.	3.	9104.	12401.	179747.	61923.	26517.	35406.	2.01	15.	SI
810.	20.	3.	-8756.	12401.	179747.	61923.	26517.	35406.	2.01	15.	SI
810.	20.	3.	8756.	12401.	179747.	61923.	26517.	35406.	2.01	15.	SI
829.	39.	3.	-8409.	12401.	179747.	61923.	26517.	35406.	2.01	15.	SI
829.	39.	3.	8409.	12401.	179747.	61923.	26517.	35406.	2.01	15.	SI
874.	84.	3.	-7574.	12401.	179747.	61923.	26517.	35406.	2.01	15.	SI
874.	84.	3.	7574.	12401.	179747.	61923.	26517.	35406.	2.01	15.	SI
920.	130.	3.	-6728.	12401.	179747.	35406.	26517.	17703.	2.01	30.	SI

920.	130.	3.	6728.	12401.	179747.	35406.	26517.	17703.	2.01	30.	SI
965.	175.	3.	-5894.	12401.	179747.	35406.	26517.	17703.	2.01	30.	SI
965.	175.	3.	5894.	12401.	179747.	35406.	26517.	17703.	2.01	30.	SI
1010.	220.	3.	-5083.	12401.	179747.	35406.	26517.	17703.	2.01	30.	SI
1010.	220.	3.	5083.	12401.	179747.	35406.	26517.	17703.	2.01	30.	SI
1055.	265.	3.	-4295.	12401.	179747.	35406.	26517.	17703.	2.01	30.	SI
1055.	265.	3.	4295.	12401.	179747.	35406.	26517.	17703.	2.01	30.	SI
1101.	311.	3.	-3518.	12401.	179747.	61923.	26517.	35406.	2.01	15.	SI
1101.	311.	3.	3518.	12401.	179747.	61923.	26517.	35406.	2.01	15.	SI
1146.	356.	3.	-2728.	12401.	179747.	61923.	26517.	35406.	2.01	15.	SI
1146.	356.	3.	2728.	12401.	179747.	61923.	26517.	35406.	2.01	15.	SI
1165.	375.	3.	-2373.	12401.	179747.	61923.	26517.	35406.	2.01	15.	SI
1165.	375.	3.	2373.	12401.	179747.	61923.	26517.	35406.	2.01	15.	SI
1185.	395.	3.	-2017.	12401.	179747.	61923.	26517.	35406.	2.01	15.	SI
1185.	395.	3.	2017.	12401.	179747.	61923.	26517.	35406.	2.01	15.	SI
>1185.	0.	3.	-12017.	12401.	179747.	61923.	26517.	35406.	2.01	15.	SI
1185.	0.	3.	12017.	12401.	179747.	61923.	26517.	35406.	2.01	15.	SI
1205.	20.	3.	-11630.	12401.	179747.	61923.	26517.	35406.	2.01	15.	SI
1205.	20.	3.	11630.	12401.	179747.	61923.	26517.	35406.	2.01	15.	SI
1224.	39.	3.	-11243.	12401.	179747.	61923.	26517.	35406.	2.01	15.	SI
1224.	39.	3.	11243.	12401.	179747.	61923.	26517.	35406.	2.01	15.	SI
1269.	84.	3.	-10335.	12401.	179747.	61923.	26517.	35406.	2.01	15.	SI
1269.	84.	3.	10335.	12401.	179747.	61923.	26517.	35406.	2.01	15.	SI
1315.	130.	3.	-9453.	12401.	179747.	35406.	26517.	17703.	2.01	30.	SI
1315.	130.	3.	9453.	12401.	179747.	35406.	26517.	17703.	2.01	30.	SI
1360.	175.	3.	-8629.	12401.	179747.	35406.	26517.	17703.	2.01	30.	SI
1360.	175.	3.	8629.	12401.	179747.	35406.	26517.	17703.	2.01	30.	SI
1405.	220.	3.	-7880.	12401.	179747.	35406.	26517.	17703.	2.01	30.	SI
1405.	220.	3.	7880.	12401.	179747.	35406.	26517.	17703.	2.01	30.	SI
1450.	265.	3.	-7205.	12401.	179747.	35406.	26517.	17703.	2.01	30.	SI
1450.	265.	3.	7205.	12401.	179747.	35406.	26517.	17703.	2.01	30.	SI
1496.	311.	3.	-6586.	12401.	179747.	61923.	26517.	35406.	2.01	15.	SI
1496.	311.	3.	6586.	12401.	179747.	61923.	26517.	35406.	2.01	15.	SI
1541.	356.	3.	-5988.	12401.	179747.	61923.	26517.	35406.	2.01	15.	SI
1541.	356.	3.	5988.	12401.	179747.	61923.	26517.	35406.	2.01	15.	SI
1560.	375.	3.	-5722.	12401.	179747.	61923.	26517.	35406.	2.01	15.	SI
1560.	375.	3.	5722.	12401.	179747.	61923.	26517.	35406.	2.01	15.	SI
1580.	395.	3.	-5456.	12401.	179747.	61923.	26517.	35406.	2.01	15.	SI
1580.	395.	3.	5456.	12401.	179747.	61923.	26517.	35406.	2.01	15.	SI
>1580.	0.	3.	-8023.	12401.	179747.	61923.	26517.	35406.	2.01	15.	SI
1580.	0.	3.	8023.	12401.	179747.	61923.	26517.	35406.	2.01	15.	SI
1600.	20.	3.	-7723.	12401.	179747.	61923.	26517.	35406.	2.01	15.	SI
1600.	20.	3.	7723.	12401.	179747.	61923.	26517.	35406.	2.01	15.	SI
1619.	39.	3.	-7422.	12401.	179747.	61923.	26517.	35406.	2.01	15.	SI
1619.	39.	3.	7422.	12401.	179747.	61923.	26517.	35406.	2.01	15.	SI
1664.	84.	3.	-6689.	12401.	179747.	61923.	26517.	35406.	2.01	15.	SI
1664.	84.	3.	6689.	12401.	179747.	61923.	26517.	35406.	2.01	15.	SI
1710.	130.	3.	-5936.	12401.	179747.	35406.	26517.	17703.	2.01	30.	SI
1710.	130.	3.	5936.	12401.	179747.	35406.	26517.	17703.	2.01	30.	SI
1755.	175.	3.	-5189.	12401.	179747.	35406.	26517.	17703.	2.01	30.	SI
1755.	175.	3.	5189.	12401.	179747.	35406.	26517.	17703.	2.01	30.	SI
1800.	220.	3.	-4463.	12401.	179747.	35406.	26517.	17703.	2.01	30.	SI
1800.	220.	3.	4463.	12401.	179747.	35406.	26517.	17703.	2.01	30.	SI
1845.	265.	3.	-3762.	12401.	179747.	35406.	26517.	17703.	2.01	30.	SI
1845.	265.	3.	3762.	12401.	179747.	35406.	26517.	17703.	2.01	30.	SI
1891.	311.	3.	-3080.	12401.	179747.	61923.	26517.	35406.	2.01	15.	SI
1891.	311.	3.	3080.	12401.	179747.	61923.	26517.	35406.	2.01	15.	SI
1936.	356.	3.	-2404.	12401.	179747.	61923.	26517.	35406.	2.01	15.	SI
1936.	356.	3.	2404.	12401.	179747.	61923.	26517.	35406.	2.01	15.	SI
1955.	375.	3.	-2105.	12401.	179747.	61923.	26517.	35406.	2.01	15.	SI
1955.	375.	3.	2105.	12401.	179747.	61923.	26517.	35406.	2.01	15.	SI
1975.	395.	3.	-1807.	12401.	179747.	61923.	26517.	35406.	2.01	15.	SI
1975.	395.	3.	1807.	12401.	179747.	61923.	26517.	35406.	2.01	15.	SI
>1975.	0.	3.	-11807.	12401.	179747.	61923.	26517.	35406.	2.01	15.	SI
1975.	0.	3.	11807.	12401.	179747.	61923.	26517.	35406.	2.01	15.	SI
1995.	20.	3.	-11495.	12401.	179747.	61923.	26517.	35406.	2.01	15.	SI
1995.	20.	3.	11495.	12401.	179747.	61923.	26517.	35406.	2.01	15.	SI
2014.	39.	3.	-11183.	12401.	179747.	61923.	26517.	35406.	2.01	15.	SI
2014.	39.	3.	11183.	12401.	179747.	61923.	26517.	35406.	2.01	15.	SI
2059.	84.	3.	-10495.	12401.	179747.	61923.	26517.	35406.	2.01	15.	SI
2059.	84.	3.	10495.	12401.	179747.	61923.	26517.	35406.	2.01	15.	SI
2105.	130.	3.	-9896.	12401.	179747.	35406.	26517.	17703.	2.01	30.	SI
2105.	130.	3.	9896.	12401.	179747.	35406.	26517.	17703.	2.01	30.	SI
2150.	175.	3.	-9432.	12401.	179747.	35406.	26517.	17703.	2.01	30.	SI
2150.	175.	3.	9432.	12401.	179747.	35406.	26517.	17703.	2.01	30.	SI

2195.	220.	3.	-9128.	12401.	179747.	35406.	26517.	17703.	2.01	30.	SI
2195.	220.	3.	9128.	12401.	179747.	35406.	26517.	17703.	2.01	30.	SI
2240.	265.	3.	-8991.	12401.	179747.	35406.	26517.	17703.	2.01	30.	SI
2240.	265.	3.	8991.	12401.	179747.	35406.	26517.	17703.	2.01	30.	SI
2286.	311.	3.	-9007.	12401.	179747.	61923.	26517.	35406.	2.01	15.	SI
2286.	311.	3.	9007.	12401.	179747.	61923.	26517.	35406.	2.01	15.	SI
2331.	356.	3.	-9144.	11049.	179747.	61923.	26517.	35406.	2.01	15.	SI
2331.	356.	3.	9144.	11049.	179747.	61923.	26517.	35406.	2.01	15.	SI
2350.	375.	3.	-9232.	11049.	179747.	61923.	26517.	35406.	2.01	15.	SI
2350.	375.	3.	9232.	11049.	179747.	61923.	26517.	35406.	2.01	15.	SI
2370.	395.	3.	-9320.	11049.	179747.	61923.	26517.	35406.	2.01	15.	SI
2370.	395.	3.	9320.	11049.	179747.	61923.	26517.	35406.	2.01	15.	SI

TENSIONI DI ESERCIZIO E FESSURAZIONE - RARE:

Progressive	Se	Ar	Momento	Scls	Sacc	As	hc,ef	Eps	Sr,max	Wk	Ve	
> 0.	0.	3.	1.	32361.	- .8	44.8	10.05	7.5	.013	81.93	.011	SI
20.	20.	3.	1.	-63514.	-1.2	92.3	9.42	7.5	.027	87.78	.024	SI
39.	39.	3.	1.	-159390.	-3.	231.6	9.42	7.5	.068	87.78	.06	SI
84.	84.	3.	1.	-318299.	-6.	462.6	9.42	7.5	.135	87.78	.119	SI
130.	130.	3.	1.	-406489.	-7.6	590.7	9.42	7.5	.173	87.78	.152	SI
175.	175.	3.	1.	-426923.	-8.	620.4	9.42	7.5	.182	87.78	.159	SI
220.	220.	3.	1.	-382052.	-7.2	555.2	9.42	7.5	.163	87.78	.143	SI
265.	265.	3.	1.	-273893.	-5.1	398.	9.42	7.5	.117	87.78	.102	SI
311.	311.	3.	1.	-104112.	-2.	151.3	9.42	7.5	.044	87.78	.039	SI
356.	356.	3.	1.	125896.	-3.3	174.2	10.05	7.5	.051	81.93	.042	SI
375.	375.	3.	1.	247232.	-6.5	342.1	10.05	7.5	.1	81.93	.082	SI
395.	395.	3.	1.	368568.	-9.6	510.	10.05	7.5	.149	81.93	.122	SI
> 395.	0.	3.	1.	388565.	-10.1	537.7	10.05	7.5	.157	81.93	.129	SI
415.	20.	3.	1.	287421.	-7.5	397.7	10.05	7.5	.116	81.93	.095	SI
434.	39.	3.	1.	186276.	-4.9	257.8	10.05	7.5	.075	81.93	.062	SI
479.	84.	3.	1.	845.	0.	1.2	10.05	7.5	0.	81.93	0.	SI
525.	130.	3.	1.	-128801.	-2.4	187.2	9.42	7.5	.055	87.78	.048	SI
570.	175.	3.	1.	-203813.	-3.8	296.2	9.42	7.5	.087	87.78	.076	SI
615.	220.	3.	1.	-225304.	-4.2	327.4	9.42	7.5	.096	87.78	.084	SI
660.	265.	3.	1.	-194301.	-3.6	282.4	9.42	7.5	.083	87.78	.073	SI
706.	311.	3.	1.	-111701.	-2.1	162.3	9.42	7.5	.048	87.78	.042	SI
751.	356.	3.	1.	21775.	-.6	30.1	10.05	7.5	.009	81.93	.007	SI
770.	375.	3.	1.	98107.	-2.6	135.8	10.05	7.5	.04	81.93	.033	SI
790.	395.	3.	1.	174439.	-4.6	241.4	10.05	7.5	.071	81.93	.058	SI
> 790.	0.	3.	1.	172763.	-4.5	239.1	10.05	7.5	.07	81.93	.057	SI
810.	20.	3.	1.	102328.	-2.7	141.6	10.05	7.5	.041	81.93	.034	SI
829.	39.	3.	1.	31894.	-.8	44.1	10.05	7.5	.013	81.93	.011	SI
874.	84.	3.	1.	-88121.	-1.7	128.1	9.42	7.5	.037	87.78	.033	SI
920.	130.	3.	1.	-157626.	-3.	229.1	9.42	7.5	.067	87.78	.059	SI
965.	175.	3.	1.	-176139.	-3.3	256.	9.42	7.5	.075	87.78	.066	SI
1010.	220.	3.	1.	-143065.	-2.7	207.9	9.42	7.5	.061	87.78	.053	SI
1055.	265.	3.	1.	-57758.	-1.1	83.9	9.42	7.5	.025	87.78	.022	SI
1101.	311.	3.	1.	80405.	-2.1	111.3	10.05	7.5	.033	81.93	.027	SI
1146.	356.	3.	1.	271962.	-7.1	376.3	10.05	7.5	.11	81.93	.09	SI
1165.	375.	3.	1.	374650.	-9.8	518.4	10.05	7.5	.152	81.93	.124	SI
1185.	395.	3.	1.	477339.	-12.5	660.5	10.05	7.5	.193	81.93	.158	SI
>1185.	0.	3.	1.	477339.	-12.5	660.5	10.05	7.5	.193	81.93	.158	SI
1205.	20.	3.	1.	374971.	-9.8	518.9	10.05	7.5	.152	81.93	.124	SI
1224.	39.	3.	1.	272603.	-7.1	377.2	10.05	7.5	.11	81.93	.09	SI
1269.	84.	3.	1.	81860.	-2.1	113.3	10.05	7.5	.033	81.93	.027	SI
1315.	130.	3.	1.	-55337.	-1.	80.4	9.42	7.5	.024	87.78	.021	SI
1360.	175.	3.	1.	-139449.	-2.6	202.7	9.42	7.5	.059	87.78	.052	SI
1405.	220.	3.	1.	-171029.	-3.2	248.6	9.42	7.5	.073	87.78	.064	SI
1450.	265.	3.	1.	-150659.	-2.8	218.9	9.42	7.5	.064	87.78	.056	SI
1496.	311.	3.	1.	-78881.	-1.5	114.6	9.42	7.5	.034	87.78	.029	SI
1541.	356.	3.	1.	43859.	-1.1	60.7	10.05	7.5	.018	81.93	.015	SI
1560.	375.	3.	1.	115647.	-3.	160.	10.05	7.5	.047	81.93	.038	SI
1580.	395.	3.	1.	187435.	-4.9	259.4	10.05	7.5	.076	81.93	.062	SI
>1580.	0.	3.	1.	181926.	-4.7	251.8	10.05	7.5	.074	81.93	.06	SI
1600.	20.	3.	1.	104503.	-2.7	144.6	10.05	7.5	.042	81.93	.035	SI
1619.	39.	3.	1.	27081.	-.7	37.5	10.05	7.5	.011	81.93	.009	SI
1664.	84.	3.	1.	-108528.	-2.	157.7	9.42	7.5	.046	87.78	.041	SI
1710.	130.	3.	1.	-192824.	-3.6	280.2	9.42	7.5	.082	87.78	.072	SI
1755.	175.	3.	1.	-225120.	-4.2	327.2	9.42	7.5	.096	87.78	.084	SI
1800.	220.	3.	1.	-204551.	-3.8	297.3	9.42	7.5	.087	87.78	.076	SI
1845.	265.	3.	1.	-130128.	-2.4	189.1	9.42	7.5	.055	87.78	.049	SI
1891.	311.	3.	1.	-776.	0.	1.1	9.42	7.5	0.	87.78	0.	SI
1936.	356.	3.	1.	184622.	-4.8	255.5	10.05	7.5	.075	81.93	.061	SI

1955.	375.	3.	1.	285837.	-7.5	395.5	10.05	7.5	.116	81.93	.095	SI
1975.	395.	3.	1.	387052.	-10.1	535.6	10.05	7.5	.157	81.93	.128	SI
>1975.	0.	3.	1.	360147.	-9.4	498.4	10.05	7.5	.146	81.93	.12	SI
1995.	20.	3.	1.	238978.	-6.2	330.7	10.05	7.5	.097	81.93	.079	SI
2014.	39.	3.	1.	117809.	-3.1	163.	10.05	7.5	.048	81.93	.039	SI
2059.	84.	3.	1.	-111656.	-2.1	162.3	9.42	7.5	.047	87.78	.042	SI
2105.	130.	3.	1.	-280701.	-5.3	407.9	9.42	7.5	.119	87.78	.105	SI
2150.	175.	3.	1.	-387917.	-7.3	563.8	9.42	7.5	.165	87.78	.145	SI
2195.	220.	3.	1.	-431611.	-8.1	627.2	9.42	7.5	.184	87.78	.161	SI
2240.	265.	3.	1.	-409727.	-7.7	595.4	9.42	7.5	.174	87.78	.153	SI
2286.	311.	3.	1.	-319771.	-6.	464.7	9.42	7.5	.136	87.78	.119	SI
2331.	356.	3.	1.	-158728.	-3.	230.7	9.42	7.5	.068	87.78	.059	SI
2350.	375.	3.	1.	-61779.	-1.2	89.8	9.42	7.5	.026	87.78	.023	SI
2370.	395.	3.	1.	35170.	-.9	48.7	10.05	7.5	.014	81.93	.012	SI

TENSIONI DI ESERCIZIO E FESSURAZIONE - QUASI PERMANENTI:

Progressive	Se	Ar	Momento	Scls	Sacc	As	hc,ef	Eps	Sr,max	Wk	Ve	
> 0.	0.	3.	1.	26639.	-.7	36.9	10.05	7.5	.011	81.93	.009	SI
20.	20.	3.	1.	-48519.	-.9	70.5	9.42	7.5	.021	87.78	.018	SI
39.	39.	3.	1.	-123678.	-2.3	179.7	9.42	7.5	.053	87.78	.046	SI
84.	84.	3.	1.	-248665.	-4.7	361.4	9.42	7.5	.106	87.78	.093	SI
130.	130.	3.	1.	-318852.	-6.	463.4	9.42	7.5	.136	87.78	.119	SI
175.	175.	3.	1.	-336743.	-6.3	489.4	9.42	7.5	.143	87.78	.126	SI
220.	220.	3.	1.	-304434.	-5.7	442.4	9.42	7.5	.129	87.78	.114	SI
265.	265.	3.	1.	-223677.	-4.2	325.1	9.42	7.5	.095	87.78	.084	SI
311.	311.	3.	1.	-95930.	-1.8	139.4	9.42	7.5	.041	87.78	.036	SI
356.	356.	3.	1.	77583.	-2.	107.4	10.05	7.5	.031	81.93	.026	SI
375.	375.	3.	1.	169193.	-4.4	234.1	10.05	7.5	.069	81.93	.056	SI
395.	395.	3.	1.	260803.	-6.8	360.9	10.05	7.5	.106	81.93	.087	SI
> 395.	0.	3.	1.	277937.	-7.3	384.6	10.05	7.5	.113	81.93	.092	SI
415.	20.	3.	1.	202956.	-5.3	280.9	10.05	7.5	.082	81.93	.067	SI
434.	39.	3.	1.	127976.	-3.3	177.1	10.05	7.5	.052	81.93	.042	SI
479.	84.	3.	1.	-8845.	-.2	12.9	9.42	7.5	.004	87.78	.003	SI
525.	130.	3.	1.	-103601.	-1.9	150.6	9.42	7.5	.044	87.78	.039	SI
570.	175.	3.	1.	-157191.	-2.9	228.4	9.42	7.5	.067	87.78	.059	SI
615.	220.	3.	1.	-170468.	-3.2	247.7	9.42	7.5	.073	87.78	.064	SI
660.	265.	3.	1.	-144217.	-2.7	209.6	9.42	7.5	.061	87.78	.054	SI
706.	311.	3.	1.	-79120.	-1.5	115.	9.42	7.5	.034	87.78	.03	SI
751.	356.	3.	1.	24265.	-.6	33.6	10.05	7.5	.01	81.93	.008	SI
770.	375.	3.	1.	82975.	-2.2	114.8	10.05	7.5	.034	81.93	.028	SI
790.	395.	3.	1.	141684.	-3.7	196.1	10.05	7.5	.057	81.93	.047	SI
> 790.	0.	3.	1.	141700.	-3.7	196.1	10.05	7.5	.057	81.93	.047	SI
810.	20.	3.	1.	87541.	-2.3	121.1	10.05	7.5	.035	81.93	.029	SI
829.	39.	3.	1.	33381.	-.9	46.2	10.05	7.5	.014	81.93	.011	SI
874.	84.	3.	1.	-59710.	-1.1	86.8	9.42	7.5	.025	87.78	.022	SI
920.	130.	3.	1.	-114988.	-2.2	167.1	9.42	7.5	.049	87.78	.043	SI
965.	175.	3.	1.	-132186.	-2.5	192.1	9.42	7.5	.056	87.78	.049	SI
1010.	220.	3.	1.	-110955.	-2.1	161.2	9.42	7.5	.047	87.78	.041	SI
1055.	265.	3.	1.	-50912.	-1.	74.	9.42	7.5	.022	87.78	.019	SI
1101.	311.	3.	1.	48322.	-1.3	66.9	10.05	7.5	.02	81.93	.016	SI
1146.	356.	3.	1.	187075.	-4.9	258.9	10.05	7.5	.076	81.93	.062	SI
1165.	375.	3.	1.	261754.	-6.8	362.2	10.05	7.5	.106	81.93	.087	SI
1185.	395.	3.	1.	336433.	-8.8	465.6	10.05	7.5	.136	81.93	.112	SI
>1185.	0.	3.	1.	336433.	-8.8	465.6	10.05	7.5	.136	81.93	.112	SI
1205.	20.	3.	1.	261973.	-6.8	362.5	10.05	7.5	.106	81.93	.087	SI
1224.	39.	3.	1.	187513.	-4.9	259.5	10.05	7.5	.076	81.93	.062	SI
1269.	84.	3.	1.	49315.	-1.3	68.2	10.05	7.5	.02	81.93	.016	SI
1315.	130.	3.	1.	-49259.	-.9	71.6	9.42	7.5	.021	87.78	.018	SI
1360.	175.	3.	1.	-108488.	-2.	157.7	9.42	7.5	.046	87.78	.041	SI
1405.	220.	3.	1.	-128701.	-2.4	187.	9.42	7.5	.055	87.78	.048	SI
1450.	265.	3.	1.	-110239.	-2.1	160.2	9.42	7.5	.047	87.78	.041	SI
1496.	311.	3.	1.	-53415.	-1.	77.6	9.42	7.5	.023	87.78	.02	SI
1541.	356.	3.	1.	41531.	-1.1	57.5	10.05	7.5	.017	81.93	.014	SI
1560.	375.	3.	1.	96611.	-2.5	133.7	10.05	7.5	.039	81.93	.032	SI
1580.	395.	3.	1.	151690.	-4.	209.9	10.05	7.5	.061	81.93	.05	SI
>1580.	0.	3.	1.	146715.	-3.8	203.	10.05	7.5	.059	81.93	.049	SI
1600.	20.	3.	1.	87269.	-2.3	120.8	10.05	7.5	.035	81.93	.029	SI
1619.	39.	3.	1.	27824.	-.7	38.5	10.05	7.5	.011	81.93	.009	SI
1664.	84.	3.	1.	-76998.	-1.4	111.9	9.42	7.5	.033	87.78	.029	SI
1710.	130.	3.	1.	-143236.	-2.7	208.2	9.42	7.5	.061	87.78	.053	SI
1755.	175.	3.	1.	-170355.	-3.2	247.6	9.42	7.5	.072	87.78	.064	SI
1800.	220.	3.	1.	-157694.	-3.	229.2	9.42	7.5	.067	87.78	.059	SI
1845.	265.	3.	1.	-104495.	-2.	151.9	9.42	7.5	.044	87.78	.039	SI
1891.	311.	3.	1.	-9929.	-.2	14.4	9.42	7.5	.004	87.78	.004	SI

1936.	356.	3.	1.	126877.	-3.3	175.6	10.05	7.5	.051	81.93	.042	SI
1955.	375.	3.	1.	201910.	-5.3	279.4	10.05	7.5	.082	81.93	.067	SI
1975.	395.	3.	1.	276942.	-7.2	383.2	10.05	7.5	.112	81.93	.092	SI
>1975.	0.	3.	1.	255028.	-6.7	352.9	10.05	7.5	.103	81.93	.085	SI
1995.	20.	3.	1.	163535.	-4.3	226.3	10.05	7.5	.066	81.93	.054	SI
2014.	39.	3.	1.	72043.	-1.9	99.7	10.05	7.5	.029	81.93	.024	SI
2059.	84.	3.	1.	-101092.	-1.9	146.9	9.42	7.5	.043	87.78	.038	SI
2105.	130.	3.	1.	-228331.	-4.3	331.8	9.42	7.5	.097	87.78	.085	SI
2150.	175.	3.	1.	-308439.	-5.8	448.2	9.42	7.5	.131	87.78	.115	SI
2195.	220.	3.	1.	-339939.	-6.4	494.	9.42	7.5	.145	87.78	.127	SI
2240.	265.	3.	1.	-321054.	-6.	466.6	9.42	7.5	.137	87.78	.12	SI
2286.	311.	3.	1.	-249656.	-4.7	362.8	9.42	7.5	.106	87.78	.093	SI
2331.	356.	3.	1.	-123208.	-2.3	179.1	9.42	7.5	.052	87.78	.046	SI
2350.	375.	3.	1.	-47315.	-.9	68.8	9.42	7.5	.02	87.78	.018	SI
2370.	395.	3.	1.	28578.	-.7	39.5	10.05	7.5	.012	81.93	.009	SI

Trave filo B e C

Metodo di verifica : stati limite.

Unità di misura : Kgf ; cm ; cm² ; Kgf/cm ; Kgfc/m ; Kgf/cm² ; (ferri : mm ; cm²) ;
deform.*1000.

MATERIALI

CLS : Rck =300. ; fck=249. ; fctk= 18.4 ; fctm= 26.2 ; Ec= 311769. ;
gc =1.6 ; fcd=155.6 ; fbd= 25.8 ; fctd= 11.5 ; EpsMax=3.5
ACCIAIO: FeB44k ; fk(1%)=4384.8 ; fyk=4384.8 ; Ea=2050000. ;
ga =1.15 ; fyd=3812.9 ; EpsMax=10.

TENSIONI E FESSURE MASSIME IN ESERCIZIO

GRUPPO : a (poco aggressivo).

CLS : Scls(rara)=149.4 ; Scls(quasi permanente)=112. ; fbd(esercizio)= 25.8

ACCIAIO: Sacc(rara)=3069. ; Coeff.Omogein.= 15

FESSURE: Wk(rara)=*** ; Wk(fre.)=.4 ; Wk(q.p.)=.2 ;
c/cmin= 1 [Circ. 15/10/96 N.252 B.6.2] ; kt=.4 [EN 1992-1 7.3.4].

SEZIONI UTILIZZATE

3) A T rovescio: largh.=105; alt.=80; sp.ala=30; sp.an.=35; Acls=4900 .

DESCRIZIONE CAMPATE

Cam.	Descriz.	S.ini	Sez.	S.fin	Incl.	L.assi	L.netta
1	A141	3	3	3	0	395.	357.
2	A142	3	3	3	0	395.	345.
3	A143	3	3	3	0	395.	345.
4	A144	3	3	3	0	395.	357.
5	A145	3	3	3	0	395.	357.
6	A146	3	3	3	0	395.	357.

CASI DI CARICO DA MODELLO 3D

SLU		RARE			QUASI PERMANENTI			
Nome	Descrizione	Sest	Nome	Descrizione	Sest	Nome	Descrizione	Sest
9.	Fondazioni	2.						

VERIFICHE ALLO STATO LIMITE ULTIMO

FLESSIONE:

Progressive	SE	Ar	Msd	Epscl	Epsac	Mrd	Epscl	Epsac	Cam	x/d	Mr/Ms	VE	
> 0.	0.	3.	1.	-1637647.	-.241	1.199	-2608379.	-.894	10.	2.	.082	1.593	SI
0.	0.	3.	1.	1637647.	-.417	1.157	2721097.	-1.47	10.	2.	.128	1.662	SI
20.	20.	3.	1.	-1637647.	-.241	1.199	-2608379.	-.894	10.	2.	.082	1.593	SI
20.	20.	3.	1.	1637647.	-.417	1.157	2721097.	-1.47	10.	2.	.128	1.662	SI
39.	39.	3.	1.	-1608223.	-.237	1.178	-2608379.	-.894	10.	2.	.082	1.622	SI
39.	39.	3.	1.	1608223.	-.409	1.136	2721097.	-1.47	10.	2.	.128	1.692	SI
84.	84.	3.	1.	-1352940.	-.198	.991	-2608379.	-.894	10.	2.	.082	1.928	SI
84.	84.	3.	1.	1352940.	-.342	.955	2721097.	-1.47	10.	2.	.128	2.011	SI
130.	130.	3.	1.	-1062060.	-.155	.777	-2608379.	-.894	10.	2.	.082	2.456	SI

130.	130.	3.	1.	1062060.	-.267	.749	2721097.	-1.47	10.	2.	.128	2.562	SI
175.	175.	3.	1.	-732447.	-.107	.536	-2608379.	-.894	10.	2.	.082	3.561	SI
175.	175.	3.	1.	732447.	-.182	.516	2721097.	-1.47	10.	2.	.128	3.715	SI
220.	220.	3.	1.	-406248.	-.059	.297	-2608379.	-.894	10.	2.	.082	6.421	SI
220.	220.	3.	1.	406248.	-.1	.286	2721097.	-1.47	10.	2.	.128	6.698	SI
265.	265.	3.	1.	-731794.	-.106	.536	-2608379.	-.894	10.	2.	.082	3.564	SI
265.	265.	3.	1.	731794.	-.182	.516	2721097.	-1.47	10.	2.	.128	3.718	SI
311.	311.	3.	1.	-1246699.	-.183	.913	-2608379.	-.894	10.	2.	.082	2.092	SI
311.	311.	3.	1.	1246699.	-.314	.88	2721097.	-1.47	10.	2.	.128	2.183	SI
356.	356.	3.	1.	-1800238.	-.266	1.319	-2608379.	-.894	10.	2.	.082	1.449	SI
356.	356.	3.	1.	1800238.	-.46	1.272	2721097.	-1.47	10.	2.	.128	1.512	SI
375.	375.	3.	1.	-1867425.	-.276	1.368	-2608379.	-.894	10.	2.	.082	1.397	SI
375.	375.	3.	1.	1867425.	-.478	1.32	2721097.	-1.47	10.	2.	.128	1.457	SI
395.	395.	3.	1.	-1867425.	-.276	1.368	-2608379.	-.894	10.	2.	.082	1.397	SI
395.	395.	3.	1.	1867425.	-.478	1.32	2721097.	-1.47	10.	2.	.128	1.457	SI
> 395.	0.	3.	1.	-866670.	-.126	.634	-2608379.	-.894	10.	2.	.082	3.01	SI
395.	0.	3.	1.	866670.	-.217	.611	2721097.	-1.47	10.	2.	.128	3.14	SI
415.	20.	3.	1.	-866670.	-.126	.634	-2608379.	-.894	10.	2.	.082	3.01	SI
415.	20.	3.	1.	866670.	-.217	.611	2721097.	-1.47	10.	2.	.128	3.14	SI
434.	39.	3.	1.	-859727.	-.125	.629	-2608379.	-.894	10.	2.	.082	3.034	SI
434.	39.	3.	1.	859727.	-.215	.606	2721097.	-1.47	10.	2.	.128	3.165	SI
479.	84.	3.	1.	-793741.	-.116	.581	-2608379.	-.894	10.	2.	.082	3.286	SI
479.	84.	3.	1.	793741.	-.198	.56	2721097.	-1.47	10.	2.	.128	3.428	SI
525.	130.	3.	1.	-696009.	-.101	.509	-2608379.	-.894	10.	2.	.082	3.748	SI
525.	130.	3.	1.	696009.	-.173	.491	2721097.	-1.47	10.	2.	.128	3.91	SI
570.	175.	3.	1.	-563829.	-.082	.413	-2608379.	-.894	10.	2.	.082	4.626	SI
570.	175.	3.	1.	563829.	-.14	.397	2721097.	-1.47	10.	2.	.128	4.826	SI
615.	220.	3.	1.	-397648.	-.058	.291	-2608379.	-.894	10.	2.	.082	6.56	SI
615.	220.	3.	1.	397648.	-.098	.28	2721097.	-1.47	10.	2.	.128	6.843	SI
660.	265.	3.	1.	-224222.	-.032	.164	-2608379.	-.894	10.	2.	.082	11.63	SI
660.	265.	3.	1.	224222.	-.055	.158	2721097.	-1.47	10.	2.	.128	12.14	SI
706.	311.	3.	1.	-459991.	-.067	.337	-2608379.	-.894	10.	2.	.082	5.671	SI
706.	311.	3.	1.	459991.	-.114	.324	2721097.	-1.47	10.	2.	.128	5.916	SI
751.	356.	3.	1.	-785043.	-.114	.575	-2608379.	-.894	10.	2.	.082	3.323	SI
751.	356.	3.	1.	785043.	-.196	.554	2721097.	-1.47	10.	2.	.128	3.466	SI
770.	375.	3.	1.	-824825.	-.12	.604	-2608379.	-.894	10.	2.	.082	3.162	SI
770.	375.	3.	1.	824825.	-.206	.582	2721097.	-1.47	10.	2.	.128	3.299	SI
790.	395.	3.	1.	-824825.	-.12	.604	-2608379.	-.894	10.	2.	.082	3.162	SI
790.	395.	3.	1.	824825.	-.206	.582	2721097.	-1.47	10.	2.	.128	3.299	SI
> 790.	0.	3.	1.	-531850.	-.077	.389	-2608379.	-.894	10.	2.	.082	4.904	SI
790.	0.	3.	1.	531850.	-.132	.375	2721097.	-1.47	10.	2.	.128	5.116	SI
810.	20.	3.	1.	-531850.	-.077	.389	-2608379.	-.894	10.	2.	.082	4.904	SI
810.	20.	3.	1.	531850.	-.132	.375	2721097.	-1.47	10.	2.	.128	5.116	SI
829.	39.	3.	1.	-520428.	-.076	.381	-2608379.	-.894	10.	2.	.082	5.012	SI
829.	39.	3.	1.	520428.	-.129	.367	2721097.	-1.47	10.	2.	.128	5.229	SI
874.	84.	3.	1.	-416451.	-.06	.305	-2608379.	-.894	10.	2.	.082	6.263	SI
874.	84.	3.	1.	416451.	-.103	.294	2721097.	-1.47	10.	2.	.128	6.534	SI
920.	130.	3.	1.	-278168.	-.04	.203	-2608379.	-.894	10.	2.	.082	9.377	SI
920.	130.	3.	1.	278168.	-.069	.196	2721097.	-1.47	10.	2.	.128	9.782	SI
965.	175.	3.	1.	-261924.	-.038	.192	-2608379.	-.894	10.	2.	.082	9.959	SI
965.	175.	3.	1.	261924.	-.065	.185	2721097.	-1.47	10.	2.	.128	10.39	SI
1010.	220.	3.	1.	-528806.	-.077	.387	-2608379.	-.894	10.	2.	.082	4.933	SI
1010.	220.	3.	1.	528806.	-.131	.373	2721097.	-1.47	10.	2.	.128	5.146	SI
1055.	265.	3.	1.	-859439.	-.125	.629	-2608379.	-.894	10.	2.	.082	3.035	SI
1055.	265.	3.	1.	859439.	-.215	.606	2721097.	-1.47	10.	2.	.128	3.166	SI
1101.	311.	3.	1.	-1235310.	-.181	.904	-2608379.	-.894	10.	2.	.082	2.112	SI
1101.	311.	3.	1.	1235310.	-.311	.872	2721097.	-1.47	10.	2.	.128	2.203	SI
1146.	356.	3.	1.	-1650326.	-.243	1.209	-2608379.	-.894	10.	2.	.082	1.581	SI
1146.	356.	3.	1.	1650326.	-.42	1.166	2721097.	-1.47	10.	2.	.128	1.649	SI
1165.	375.	3.	1.	-1700986.	-.251	1.246	-2608379.	-.894	10.	2.	.082	1.533	SI
1165.	375.	3.	1.	1700986.	-.433	1.202	2721097.	-1.47	10.	2.	.128	1.6	SI
1185.	395.	3.	1.	-1700986.	-.251	1.246	-2608379.	-.894	10.	2.	.082	1.533	SI
1185.	395.	3.	1.	1700986.	-.433	1.202	2721097.	-1.47	10.	2.	.128	1.6	SI
>1185.	0.	3.	1.	-1023094.	-.149	.749	-2608379.	-.894	10.	2.	.082	2.55	SI
1185.	0.	3.	1.	1023094.	-.257	.722	2721097.	-1.47	10.	2.	.128	2.66	SI
1205.	20.	3.	1.	-1023094.	-.149	.749	-2608379.	-.894	10.	2.	.082	2.55	SI
1205.	20.	3.	1.	1023094.	-.257	.722	2721097.	-1.47	10.	2.	.128	2.66	SI
1224.	39.	3.	1.	-1013055.	-.148	.742	-2608379.	-.894	10.	2.	.082	2.575	SI
1224.	39.	3.	1.	1013055.	-.254	.715	2721097.	-1.47	10.	2.	.128	2.686	SI
1269.	84.	3.	1.	-921581.	-.134	.675	-2608379.	-.894	10.	2.	.082	2.83	SI
1269.	84.	3.	1.	921581.	-.231	.65	2721097.	-1.47	10.	2.	.128	2.953	SI
1315.	130.	3.	1.	-800307.	-.117	.586	-2608379.	-.894	10.	2.	.082	3.259	SI
1315.	130.	3.	1.	800307.	-.2	.564	2721097.	-1.47	10.	2.	.128	3.4	SI
1360.	175.	3.	1.	-647241.	-.094	.474	-2608379.	-.894	10.	2.	.082	4.03	SI
1360.	175.	3.	1.	647241.	-.161	.456	2721097.	-1.47	10.	2.	.128	4.204	SI

1405.	220.	3.	1.	-463226.	-.067	.339	-2608379.	-.894	10.	2.	.082	5.631	SI
1405.	220.	3.	1.	463226.	-.115	.326	2721097.	-1.47	10.	2.	.128	5.874	SI
1450.	265.	3.	1.	-268526.	-.039	.196	-2608379.	-.894	10.	2.	.082	9.714	SI
1450.	265.	3.	1.	268526.	-.066	.189	2721097.	-1.47	10.	2.	.128	10.13	SI
1496.	311.	3.	1.	-430591.	-.062	.315	-2608379.	-.894	10.	2.	.082	6.058	SI
1496.	311.	3.	1.	430591.	-.107	.303	2721097.	-1.47	10.	2.	.128	6.319	SI
1541.	356.	3.	1.	-758971.	-.11	.555	-2608379.	-.894	10.	2.	.082	3.437	SI
1541.	356.	3.	1.	758971.	-.189	.535	2721097.	-1.47	10.	2.	.128	3.585	SI
1560.	375.	3.	1.	-799067.	-.116	.585	-2608379.	-.894	10.	2.	.082	3.264	SI
1560.	375.	3.	1.	799067.	-.199	.564	2721097.	-1.47	10.	2.	.128	3.405	SI
1580.	395.	3.	1.	-799067.	-.116	.585	-2608379.	-.894	10.	2.	.082	3.264	SI
1580.	395.	3.	1.	799067.	-.199	.564	2721097.	-1.47	10.	2.	.128	3.405	SI
>1580.	0.	3.	1.	-478807.	-.069	.35	-2608379.	-.894	10.	2.	.082	5.448	SI
1580.	0.	3.	1.	478807.	-.119	.337	2721097.	-1.47	10.	2.	.128	5.683	SI
1600.	20.	3.	1.	-478807.	-.069	.35	-2608379.	-.894	10.	2.	.082	5.448	SI
1600.	20.	3.	1.	478807.	-.119	.337	2721097.	-1.47	10.	2.	.128	5.683	SI
1619.	39.	3.	1.	-468660.	-.068	.343	-2608379.	-.894	10.	2.	.082	5.566	SI
1619.	39.	3.	1.	468660.	-.116	.33	2721097.	-1.47	10.	2.	.128	5.806	SI
1664.	84.	3.	1.	-376002.	-.054	.275	-2608379.	-.894	10.	2.	.082	6.937	SI
1664.	84.	3.	1.	376002.	-.093	.265	2721097.	-1.47	10.	2.	.128	7.237	SI
1710.	130.	3.	1.	-251646.	-.036	.184	-2608379.	-.894	10.	2.	.082	10.37	SI
1710.	130.	3.	1.	251646.	-.062	.177	2721097.	-1.47	10.	2.	.128	10.81	SI
1755.	175.	3.	1.	-238932.	-.035	.175	-2608379.	-.894	10.	2.	.082	10.92	SI
1755.	175.	3.	1.	238932.	-.059	.168	2721097.	-1.47	10.	2.	.128	11.39	SI
1800.	220.	3.	1.	-482935.	-.07	.353	-2608379.	-.894	10.	2.	.082	5.401	SI
1800.	220.	3.	1.	482935.	-.12	.34	2721097.	-1.47	10.	2.	.128	5.635	SI
1845.	265.	3.	1.	-785773.	-.114	.575	-2608379.	-.894	10.	2.	.082	3.32	SI
1845.	265.	3.	1.	785773.	-.196	.554	2721097.	-1.47	10.	2.	.128	3.463	SI
1891.	311.	3.	1.	-1130759.	-.165	.828	-2608379.	-.894	10.	2.	.082	2.307	SI
1891.	311.	3.	1.	1130759.	-.284	.798	2721097.	-1.47	10.	2.	.128	2.406	SI
1936.	356.	3.	1.	-1512286.	-.222	1.107	-2608379.	-.894	10.	2.	.082	1.725	SI
1936.	356.	3.	1.	1512286.	-.383	1.068	2721097.	-1.47	10.	2.	.128	1.799	SI
1955.	375.	3.	1.	-1558875.	-.229	1.142	-2608379.	-.894	10.	2.	.082	1.673	SI
1955.	375.	3.	1.	1558875.	-.396	1.101	2721097.	-1.47	10.	2.	.128	1.746	SI
1975.	395.	3.	1.	-1558875.	-.229	1.142	-2608379.	-.894	10.	2.	.082	1.673	SI
1975.	395.	3.	1.	1558875.	-.396	1.101	2721097.	-1.47	10.	2.	.128	1.746	SI
>1975.	0.	3.	1.	-1177613.	-.172	.862	-2608379.	-.894	10.	2.	.082	2.215	SI
1975.	0.	3.	1.	1177613.	-.296	.831	2721097.	-1.47	10.	2.	.128	2.311	SI
1995.	20.	3.	1.	-1177613.	-.172	.862	-2608379.	-.894	10.	2.	.082	2.215	SI
1995.	20.	3.	1.	1177613.	-.296	.831	2721097.	-1.47	10.	2.	.128	2.311	SI
2014.	39.	3.	1.	-1153564.	-.169	.844	-2608379.	-.894	10.	2.	.082	2.261	SI
2014.	39.	3.	1.	1153564.	-.29	.814	2721097.	-1.47	10.	2.	.128	2.359	SI
2059.	84.	3.	1.	-945043.	-.138	.692	-2608379.	-.894	10.	2.	.082	2.76	SI
2059.	84.	3.	1.	945043.	-.237	.667	2721097.	-1.47	10.	2.	.128	2.879	SI
2105.	130.	3.	1.	-707914.	-.103	.518	-2608379.	-.894	10.	2.	.082	3.685	SI
2105.	130.	3.	1.	707914.	-.176	.499	2721097.	-1.47	10.	2.	.128	3.844	SI
2150.	175.	3.	1.	-439613.	-.064	.322	-2608379.	-.894	10.	2.	.082	5.933	SI
2150.	175.	3.	1.	439613.	-.109	.31	2721097.	-1.47	10.	2.	.128	6.19	SI
2195.	220.	3.	1.	-384474.	-.056	.281	-2608379.	-.894	10.	2.	.082	6.784	SI
2195.	220.	3.	1.	384474.	-.095	.271	2721097.	-1.47	10.	2.	.128	7.077	SI
2240.	265.	3.	1.	-744606.	-.108	.545	-2608379.	-.894	10.	2.	.082	3.503	SI
2240.	265.	3.	1.	744606.	-.186	.525	2721097.	-1.47	10.	2.	.128	3.654	SI
2286.	311.	3.	1.	-1156072.	-.169	.846	-2608379.	-.894	10.	2.	.082	2.256	SI
2286.	311.	3.	1.	1156072.	-.291	.816	2721097.	-1.47	10.	2.	.128	2.354	SI
2331.	356.	3.	1.	-1595035.	-.235	1.168	-2608379.	-.894	10.	2.	.082	1.635	SI
2331.	356.	3.	1.	1595035.	-.405	1.127	2721097.	-1.47	10.	2.	.128	1.706	SI
2350.	375.	3.	1.	-1648215.	-.243	1.207	-2608379.	-.894	10.	2.	.082	1.583	SI
2350.	375.	3.	1.	1648215.	-.419	1.164	2721097.	-1.47	10.	2.	.128	1.651	SI
2370.	395.	3.	1.	-1648215.	-.243	1.207	-2608379.	-.894	10.	2.	.082	1.583	SI
2370.	395.	3.	1.	1648215.	-.419	1.164	2721097.	-1.47	10.	2.	.128	1.651	SI

VERIFICHE A TAGLIO

TAGLIO:

Progressive	Se	Vsd	VRd1	VRd2	Vrd3	Vcd	Vwd	Asw	s	Ve		
>	0.	0.	3.	-4917.	7533.	122555.	34498.	18080.	17249.	1.01	15.	SI
	0.	0.	3.	4917.	7533.	122555.	34498.	18080.	17249.	1.01	15.	SI
	20.	20.	3.	-5329.	7533.	122555.	34498.	18080.	17249.	1.01	15.	SI
	20.	20.	3.	5329.	7533.	122555.	34498.	18080.	17249.	1.01	15.	SI
	39.	39.	3.	-5742.	7533.	122555.	34498.	18080.	17249.	1.01	15.	SI
	39.	39.	3.	5742.	7533.	122555.	34498.	18080.	17249.	1.01	15.	SI
	84.	84.	3.	-6627.	8886.	122555.	34498.	18080.	17249.	1.01	15.	SI
	84.	84.	3.	6627.	8886.	122555.	34498.	18080.	17249.	1.01	15.	SI
	130.	130.	3.	-7482.	8886.	122555.	24641.	18080.	12321.	1.01	21.	SI

130.	130.	3.	7482.	8886.	122555.	24641.	18080.	12321.	1.01	21.	SI
175.	175.	3.	-8348.	8886.	122555.	24641.	18080.	12321.	1.01	21.	SI
175.	175.	3.	8348.	8886.	122555.	24641.	18080.	12321.	1.01	21.	SI
220.	220.	3.	-9249.	8886.	122555.	24641.	18080.	12321.	1.01	21.	SI
220.	220.	3.	9249.	8886.	122555.	24641.	18080.	12321.	1.01	21.	SI
265.	265.	3.	-10191.	8886.	122555.	24641.	18080.	12321.	1.01	21.	SI
265.	265.	3.	10191.	8886.	122555.	24641.	18080.	12321.	1.01	21.	SI
311.	311.	3.	-11163.	8886.	122555.	34498.	18080.	17249.	1.01	15.	SI
311.	311.	3.	11163.	8886.	122555.	34498.	18080.	17249.	1.01	15.	SI
356.	356.	3.	-12135.	8886.	122555.	34498.	18080.	17249.	1.01	15.	SI
356.	356.	3.	12135.	8886.	122555.	34498.	18080.	17249.	1.01	15.	SI
375.	375.	3.	-12541.	8886.	122555.	34498.	18080.	17249.	1.01	15.	SI
375.	375.	3.	12541.	8886.	122555.	34498.	18080.	17249.	1.01	15.	SI
395.	395.	3.	-12947.	8886.	122555.	34498.	18080.	17249.	1.01	15.	SI
395.	395.	3.	12947.	8886.	122555.	34498.	18080.	17249.	1.01	15.	SI
> 395.	0.	3.	-818.	8886.	122555.	34498.	18080.	17249.	1.01	15.	SI
395.	0.	3.	818.	8886.	122555.	34498.	18080.	17249.	1.01	15.	SI
415.	20.	3.	-1182.	8886.	122555.	34498.	18080.	17249.	1.01	15.	SI
415.	20.	3.	1182.	8886.	122555.	34498.	18080.	17249.	1.01	15.	SI
434.	39.	3.	-1547.	8886.	122555.	34498.	18080.	17249.	1.01	15.	SI
434.	39.	3.	1547.	8886.	122555.	34498.	18080.	17249.	1.01	15.	SI
479.	84.	3.	-2338.	8886.	122555.	34498.	18080.	17249.	1.01	15.	SI
479.	84.	3.	2338.	8886.	122555.	34498.	18080.	17249.	1.01	15.	SI
525.	130.	3.	-3097.	8886.	122555.	24641.	18080.	12321.	1.01	21.	SI
525.	130.	3.	3097.	8886.	122555.	24641.	18080.	12321.	1.01	21.	SI
570.	175.	3.	-3853.	8886.	122555.	24641.	18080.	12321.	1.01	21.	SI
570.	175.	3.	3853.	8886.	122555.	24641.	18080.	12321.	1.01	21.	SI
615.	220.	3.	-4625.	8886.	122555.	24641.	18080.	12321.	1.01	21.	SI
615.	220.	3.	4625.	8886.	122555.	24641.	18080.	12321.	1.01	21.	SI
660.	265.	3.	-5423.	8886.	122555.	24641.	18080.	12321.	1.01	21.	SI
660.	265.	3.	5423.	8886.	122555.	24641.	18080.	12321.	1.01	21.	SI
706.	311.	3.	-6248.	8886.	122555.	34498.	18080.	17249.	1.01	15.	SI
706.	311.	3.	6248.	8886.	122555.	34498.	18080.	17249.	1.01	15.	SI
751.	356.	3.	-7094.	8886.	122555.	34498.	18080.	17249.	1.01	15.	SI
751.	356.	3.	7094.	8886.	122555.	34498.	18080.	17249.	1.01	15.	SI
770.	375.	3.	-7463.	8886.	122555.	34498.	18080.	17249.	1.01	15.	SI
770.	375.	3.	7463.	8886.	122555.	34498.	18080.	17249.	1.01	15.	SI
790.	395.	3.	-7832.	8886.	122555.	34498.	18080.	17249.	1.01	15.	SI
790.	395.	3.	7832.	8886.	122555.	34498.	18080.	17249.	1.01	15.	SI
> 790.	0.	3.	-1654.	8886.	122555.	34498.	18080.	17249.	1.01	15.	SI
790.	0.	3.	1654.	8886.	122555.	34498.	18080.	17249.	1.01	15.	SI
810.	20.	3.	-2020.	8886.	122555.	34498.	18080.	17249.	1.01	15.	SI
810.	20.	3.	2020.	8886.	122555.	34498.	18080.	17249.	1.01	15.	SI
829.	39.	3.	-2386.	8886.	122555.	34498.	18080.	17249.	1.01	15.	SI
829.	39.	3.	2386.	8886.	122555.	34498.	18080.	17249.	1.01	15.	SI
874.	84.	3.	-3246.	8886.	122555.	34498.	18080.	17249.	1.01	15.	SI
874.	84.	3.	3246.	8886.	122555.	34498.	18080.	17249.	1.01	15.	SI
920.	130.	3.	-4141.	8886.	122555.	24641.	18080.	12321.	1.01	21.	SI
920.	130.	3.	4141.	8886.	122555.	24641.	18080.	12321.	1.01	21.	SI
965.	175.	3.	-5079.	8886.	122555.	24641.	18080.	12321.	1.01	21.	SI
965.	175.	3.	5079.	8886.	122555.	24641.	18080.	12321.	1.01	21.	SI
1010.	220.	3.	-6061.	8886.	122555.	24641.	18080.	12321.	1.01	21.	SI
1010.	220.	3.	6061.	8886.	122555.	24641.	18080.	12321.	1.01	21.	SI
1055.	265.	3.	-7072.	8886.	122555.	24641.	18080.	12321.	1.01	21.	SI
1055.	265.	3.	7072.	8886.	122555.	24641.	18080.	12321.	1.01	21.	SI
1101.	311.	3.	-8089.	8886.	122555.	34498.	18080.	17249.	1.01	15.	SI
1101.	311.	3.	8089.	8886.	122555.	34498.	18080.	17249.	1.01	15.	SI
1146.	356.	3.	-9075.	8886.	122555.	34498.	18080.	17249.	1.01	15.	SI
1146.	356.	3.	9075.	8886.	122555.	34498.	18080.	17249.	1.01	15.	SI
1165.	375.	3.	-9476.	8886.	122555.	34498.	18080.	17249.	1.01	15.	SI
1165.	375.	3.	9476.	8886.	122555.	34498.	18080.	17249.	1.01	15.	SI
1185.	395.	3.	-9878.	8886.	122555.	34498.	18080.	17249.	1.01	15.	SI
1185.	395.	3.	9878.	8886.	122555.	34498.	18080.	17249.	1.01	15.	SI
>1185.	0.	3.	-1409.	8886.	122555.	34498.	18080.	17249.	1.01	15.	SI
1185.	0.	3.	1409.	8886.	122555.	34498.	18080.	17249.	1.01	15.	SI
1205.	20.	3.	-1758.	8886.	122555.	34498.	18080.	17249.	1.01	15.	SI
1205.	20.	3.	1758.	8886.	122555.	34498.	18080.	17249.	1.01	15.	SI
1224.	39.	3.	-2106.	8886.	122555.	34498.	18080.	17249.	1.01	15.	SI
1224.	39.	3.	2106.	8886.	122555.	34498.	18080.	17249.	1.01	15.	SI
1269.	84.	3.	-2847.	8886.	122555.	34498.	18080.	17249.	1.01	15.	SI
1269.	84.	3.	2847.	8886.	122555.	34498.	18080.	17249.	1.01	15.	SI
1315.	130.	3.	-3545.	8886.	122555.	24641.	18080.	12321.	1.01	21.	SI
1315.	130.	3.	3545.	8886.	122555.	24641.	18080.	12321.	1.01	21.	SI
1360.	175.	3.	-4231.	8886.	122555.	24641.	18080.	12321.	1.01	21.	SI
1360.	175.	3.	4231.	8886.	122555.	24641.	18080.	12321.	1.01	21.	SI

1405.	220.	3.	-4928.	8886.	122555.	24641.	18080.	12321.	1.01	21.	SI
1405.	220.	3.	4928.	8886.	122555.	24641.	18080.	12321.	1.01	21.	SI
1450.	265.	3.	-5651.	8886.	122555.	24641.	18080.	12321.	1.01	21.	SI
1450.	265.	3.	5651.	8886.	122555.	24641.	18080.	12321.	1.01	21.	SI
1496.	311.	3.	-6401.	8886.	122555.	34498.	18080.	17249.	1.01	15.	SI
1496.	311.	3.	6401.	8886.	122555.	34498.	18080.	17249.	1.01	15.	SI
1541.	356.	3.	-7175.	8886.	122555.	34498.	18080.	17249.	1.01	15.	SI
1541.	356.	3.	7175.	8886.	122555.	34498.	18080.	17249.	1.01	15.	SI
1560.	375.	3.	-7514.	8886.	122555.	34498.	18080.	17249.	1.01	15.	SI
1560.	375.	3.	7514.	8886.	122555.	34498.	18080.	17249.	1.01	15.	SI
1580.	395.	3.	-7853.	8886.	122555.	34498.	18080.	17249.	1.01	15.	SI
1580.	395.	3.	7853.	8886.	122555.	34498.	18080.	17249.	1.01	15.	SI
>1580.	0.	3.	-1454.	8886.	122555.	34498.	18080.	17249.	1.01	15.	SI
1580.	0.	3.	1454.	8886.	122555.	34498.	18080.	17249.	1.01	15.	SI
1600.	20.	3.	-1791.	8886.	122555.	34498.	18080.	17249.	1.01	15.	SI
1600.	20.	3.	1791.	8886.	122555.	34498.	18080.	17249.	1.01	15.	SI
1619.	39.	3.	-2129.	8886.	122555.	34498.	18080.	17249.	1.01	15.	SI
1619.	39.	3.	2129.	8886.	122555.	34498.	18080.	17249.	1.01	15.	SI
1664.	84.	3.	-2924.	8886.	122555.	34498.	18080.	17249.	1.01	15.	SI
1664.	84.	3.	2924.	8886.	122555.	34498.	18080.	17249.	1.01	15.	SI
1710.	130.	3.	-3752.	8886.	122555.	24641.	18080.	12321.	1.01	21.	SI
1710.	130.	3.	3752.	8886.	122555.	24641.	18080.	12321.	1.01	21.	SI
1755.	175.	3.	-4623.	8886.	122555.	24641.	18080.	12321.	1.01	21.	SI
1755.	175.	3.	4623.	8886.	122555.	24641.	18080.	12321.	1.01	21.	SI
1800.	220.	3.	-5534.	8886.	122555.	24641.	18080.	12321.	1.01	21.	SI
1800.	220.	3.	5534.	8886.	122555.	24641.	18080.	12321.	1.01	21.	SI
1845.	265.	3.	-6474.	8886.	122555.	24641.	18080.	12321.	1.01	21.	SI
1845.	265.	3.	6474.	8886.	122555.	24641.	18080.	12321.	1.01	21.	SI
1891.	311.	3.	-7420.	8886.	122555.	34498.	18080.	17249.	1.01	15.	SI
1891.	311.	3.	7420.	8886.	122555.	34498.	18080.	17249.	1.01	15.	SI
1936.	356.	3.	-8341.	8886.	122555.	34498.	18080.	17249.	1.01	15.	SI
1936.	356.	3.	8341.	8886.	122555.	34498.	18080.	17249.	1.01	15.	SI
1955.	375.	3.	-8717.	8886.	122555.	34498.	18080.	17249.	1.01	15.	SI
1955.	375.	3.	8717.	8886.	122555.	34498.	18080.	17249.	1.01	15.	SI
1975.	395.	3.	-9093.	8886.	122555.	34498.	18080.	17249.	1.01	15.	SI
1975.	395.	3.	9093.	8886.	122555.	34498.	18080.	17249.	1.01	15.	SI
>1975.	0.	3.	-4029.	8886.	122555.	34498.	18080.	17249.	1.01	15.	SI
1975.	0.	3.	4029.	8886.	122555.	34498.	18080.	17249.	1.01	15.	SI
1995.	20.	3.	-4359.	8886.	122555.	34498.	18080.	17249.	1.01	15.	SI
1995.	20.	3.	4359.	8886.	122555.	34498.	18080.	17249.	1.01	15.	SI
2014.	39.	3.	-4688.	8886.	122555.	34498.	18080.	17249.	1.01	15.	SI
2014.	39.	3.	4688.	8886.	122555.	34498.	18080.	17249.	1.01	15.	SI
2059.	84.	3.	-5401.	8886.	122555.	34498.	18080.	17249.	1.01	15.	SI
2059.	84.	3.	5401.	8886.	122555.	34498.	18080.	17249.	1.01	15.	SI
2105.	130.	3.	-6089.	8886.	122555.	24641.	18080.	12321.	1.01	21.	SI
2105.	130.	3.	6089.	8886.	122555.	24641.	18080.	12321.	1.01	21.	SI
2150.	175.	3.	-6781.	8886.	122555.	24641.	18080.	12321.	1.01	21.	SI
2150.	175.	3.	6781.	8886.	122555.	24641.	18080.	12321.	1.01	21.	SI
2195.	220.	3.	-7490.	8886.	122555.	24641.	18080.	12321.	1.01	21.	SI
2195.	220.	3.	7490.	8886.	122555.	24641.	18080.	12321.	1.01	21.	SI
2240.	265.	3.	-8216.	8886.	122555.	24641.	18080.	12321.	1.01	21.	SI
2240.	265.	3.	8216.	8886.	122555.	24641.	18080.	12321.	1.01	21.	SI
2286.	311.	3.	-8941.	8886.	122555.	34498.	18080.	17249.	1.01	15.	SI
2286.	311.	3.	8941.	8886.	122555.	34498.	18080.	17249.	1.01	15.	SI
2331.	356.	3.	-9635.	8886.	122555.	34498.	18080.	17249.	1.01	15.	SI
2331.	356.	3.	9635.	8886.	122555.	34498.	18080.	17249.	1.01	15.	SI
2350.	375.	3.	-9911.	7533.	122555.	34498.	18080.	17249.	1.01	15.	SI
2350.	375.	3.	9911.	7533.	122555.	34498.	18080.	17249.	1.01	15.	SI
2370.	395.	3.	-10186.	7533.	122555.	34498.	18080.	17249.	1.01	15.	SI
2370.	395.	3.	10186.	7533.	122555.	34498.	18080.	17249.	1.01	15.	SI

TENSIONI DI ESERCIZIO E FESSURAZIONE - RARE:

Progressive	Se	Ar	Momento	Scls	Sacc	As	hc,ef	Eps	Sr,max	Wk	Ve	
> 0.	0.	3.	1.	-2061.	0.	3.1	9.42	12.5	.001	29.38	0.	SI
20.	20.	3.	1.	-51588.	-1.	77.3	9.42	12.5	.023	29.38	.007	SI
39.	39.	3.	1.	-101116.	-2.	151.5	9.42	12.5	.044	29.38	.013	SI
84.	84.	3.	1.	-176430.	-3.4	264.3	9.42	12.5	.077	29.38	.023	SI
130.	130.	3.	1.	-205019.	-4.	307.2	9.42	12.5	.09	29.38	.026	SI
175.	175.	3.	1.	-185712.	-3.6	278.2	9.42	12.5	.081	29.38	.024	SI
220.	220.	3.	1.	-117117.	-2.3	175.5	9.42	12.5	.051	29.38	.015	SI
265.	265.	3.	1.	2235.	-.1	3.2	10.05	12.5	.001	49.79	0.	SI
311.	311.	3.	1.	173751.	-5.8	250.9	10.05	12.5	.073	49.79	.037	SI

356.	356.	3.	1.	398639.	-13.3	575.6	10.05	12.5	.168	49.79	.084	SI
375.	375.	3.	1.	515905.	-17.2	744.9	10.05	12.5	.218	49.79	.109	SI
395.	395.	3.	1.	633172.	-21.1	914.2	10.05	12.5	.268	49.79	.133	SI
> 395.	0.	3.	1.	631303.	-21.1	911.6	10.05	12.5	.267	49.79	.133	SI
415.	20.	3.	1.	513326.	-17.1	741.2	10.05	12.5	.217	49.79	.108	SI
434.	39.	3.	1.	395348.	-13.2	570.9	10.05	12.5	.167	49.79	.083	SI
479.	84.	3.	1.	169048.	-5.6	244.1	10.05	12.5	.071	49.79	.036	SI
525.	130.	3.	1.	-3388.	-.1	5.1	9.42	12.5	.001	29.38	0.	SI
570.	175.	3.	1.	-122901.	-2.4	184.1	9.42	12.5	.054	29.38	.016	SI
615.	220.	3.	1.	-190623.	-3.7	285.6	9.42	12.5	.084	29.38	.025	SI
660.	265.	3.	1.	-207746.	-4.	311.3	9.42	12.5	.091	29.38	.027	SI
706.	311.	3.	1.	-175376.	-3.4	262.8	9.42	12.5	.077	29.38	.023	SI
751.	356.	3.	1.	-94405.	-1.8	141.4	9.42	12.5	.041	29.38	.012	SI
770.	375.	3.	1.	-41653.	-.8	62.4	9.42	12.5	.018	29.38	.005	SI
790.	395.	3.	1.	11099.	-.4	16.	10.05	12.5	.005	49.79	.002	SI
> 790.	0.	3.	1.	1653.	-.1	2.4	10.05	12.5	.001	49.79	0.	SI
810.	20.	3.	1.	-49609.	-1.	74.3	9.42	12.5	.022	29.38	.006	SI
829.	39.	3.	1.	-100871.	-2.	151.1	9.42	12.5	.044	29.38	.013	SI
874.	84.	3.	1.	-177935.	-3.5	266.6	9.42	12.5	.078	29.38	.023	SI
920.	130.	3.	1.	-205428.	-4.	307.8	9.42	12.5	.09	29.38	.026	SI
965.	175.	3.	1.	-181939.	-3.5	272.6	9.42	12.5	.08	29.38	.023	SI
1010.	220.	3.	1.	-105851.	-2.1	158.6	9.42	12.5	.046	29.38	.014	SI
1055.	265.	3.	1.	24510.	-.8	35.4	10.05	12.5	.01	49.79	.005	SI
1101.	311.	3.	1.	210715.	-7.	304.3	10.05	12.5	.089	49.79	.044	SI
1146.	356.	3.	1.	454085.	-15.1	655.7	10.05	12.5	.192	49.79	.096	SI
1165.	375.	3.	1.	580760.	-19.4	838.6	10.05	12.5	.245	49.79	.122	SI
1185.	395.	3.	1.	707436.	-23.6	1021.5	10.05	12.5	.299	49.79	.149	SI
>1185.	0.	3.	1.	703026.	-23.4	1015.1	10.05	12.5	.297	49.79	.148	SI
1205.	20.	3.	1.	576954.	-19.2	833.1	10.05	12.5	.244	49.79	.121	SI
1224.	39.	3.	1.	450882.	-15.	651.	10.05	12.5	.191	49.79	.095	SI
1269.	84.	3.	1.	208964.	-7.	301.7	10.05	12.5	.088	49.79	.044	SI
1315.	130.	3.	1.	24331.	-.8	35.1	10.05	12.5	.01	49.79	.005	SI
1360.	175.	3.	1.	-104263.	-2.	156.2	9.42	12.5	.046	29.38	.013	SI
1405.	220.	3.	1.	-178324.	-3.5	267.2	9.42	12.5	.078	29.38	.023	SI
1450.	265.	3.	1.	-199456.	-3.9	298.8	9.42	12.5	.087	29.38	.026	SI
1496.	311.	3.	1.	-169222.	-3.3	253.5	9.42	12.5	.074	29.38	.022	SI
1541.	356.	3.	1.	-88986.	-1.7	133.3	9.42	12.5	.039	29.38	.011	SI
1560.	375.	3.	1.	-36183.	-.7	54.2	9.42	12.5	.016	29.38	.005	SI
1580.	395.	3.	1.	16620.	-.6	24.	10.05	12.5	.007	49.79	.003	SI
>1580.	0.	3.	1.	17117.	-.6	24.7	10.05	12.5	.007	49.79	.004	SI
1600.	20.	3.	1.	-36452.	-.7	54.6	9.42	12.5	.016	29.38	.005	SI
1619.	39.	3.	1.	-90021.	-1.8	134.9	9.42	12.5	.039	29.38	.012	SI
1664.	84.	3.	1.	-172488.	-3.4	258.4	9.42	12.5	.076	29.38	.022	SI
1710.	130.	3.	1.	-205906.	-4.	308.5	9.42	12.5	.09	29.38	.027	SI
1755.	175.	3.	1.	-189403.	-3.7	283.8	9.42	12.5	.083	29.38	.024	SI
1800.	220.	3.	1.	-121894.	-2.4	182.6	9.42	12.5	.053	29.38	.016	SI
1845.	265.	3.	1.	-2217.	0.	3.3	9.42	12.5	.001	29.38	0.	SI
1891.	311.	3.	1.	170728.	-5.7	246.5	10.05	12.5	.072	49.79	.036	SI
1936.	356.	3.	1.	397848.	-13.3	574.5	10.05	12.5	.168	49.79	.084	SI
1955.	375.	3.	1.	516283.	-17.2	745.5	10.05	12.5	.218	49.79	.109	SI
1975.	395.	3.	1.	634718.	-21.2	916.5	10.05	12.5	.268	49.79	.134	SI
>1975.	0.	3.	1.	635537.	-21.2	917.7	10.05	12.5	.269	49.79	.134	SI
1995.	20.	3.	1.	518135.	-17.3	748.1	10.05	12.5	.219	49.79	.109	SI
2014.	39.	3.	1.	400734.	-13.4	578.6	10.05	12.5	.169	49.79	.084	SI
2059.	84.	3.	1.	175690.	-5.9	253.7	10.05	12.5	.074	49.79	.037	SI
2105.	130.	3.	1.	4166.	-.1	6.	10.05	12.5	.002	49.79	.001	SI
2150.	175.	3.	1.	-115098.	-2.2	172.4	9.42	12.5	.05	29.38	.015	SI
2195.	220.	3.	1.	-183564.	-3.6	275.	9.42	12.5	.08	29.38	.024	SI
2240.	265.	3.	1.	-202760.	-3.9	303.8	9.42	12.5	.089	29.38	.026	SI
2286.	311.	3.	1.	-174137.	-3.4	260.9	9.42	12.5	.076	29.38	.022	SI
2331.	356.	3.	1.	-98933.	-1.9	148.2	9.42	12.5	.043	29.38	.013	SI
2350.	375.	3.	1.	-49529.	-1.	74.2	9.42	12.5	.022	29.38	.006	SI
2370.	395.	3.	1.	-124.	0.	.2	9.42	12.5	0.	29.38	0.	SI

TENSIONI DI ESERCIZIO E FESSURAZIONE - QUASI PERMANENTI:

Progressive	Se	Ar	Momento	Scls	Sacc	As	hc,ef	Eps	Sr,max	Wk	Ve	
> 0.	0.	3.	1.	-919.	0.	1.4	9.42	12.5	0.	29.38	0.	SI
20.	20.	3.	1.	-37106.	-.7	55.6	9.42	12.5	.016	29.38	.005	SI
39.	39.	3.	1.	-73293.	-1.4	109.8	9.42	12.5	.032	29.38	.009	SI
84.	84.	3.	1.	-128417.	-2.5	192.4	9.42	12.5	.056	29.38	.017	SI
130.	130.	3.	1.	-149570.	-2.9	224.1	9.42	12.5	.066	29.38	.019	SI
175.	175.	3.	1.	-135968.	-2.6	203.7	9.42	12.5	.06	29.38	.018	SI
220.	220.	3.	1.	-86664.	-1.7	129.8	9.42	12.5	.038	29.38	.011	SI
265.	265.	3.	1.	-651.	0.	1.	9.42	12.5	0.	29.38	0.	SI

	311.	311.	3.	1.	123036.	-4.1	177.7	10.05	12.5	.052	49.79	.026	SI
	356.	356.	3.	1.	285221.	-9.5	411.8	10.05	12.5	.121	49.79	.06	SI
	375.	375.	3.	1.	369781.	-12.3	533.9	10.05	12.5	.156	49.79	.078	SI
	395.	395.	3.	1.	454341.	-15.1	656.	10.05	12.5	.192	49.79	.096	SI
>	395.	0.	3.	1.	453257.	-15.1	654.5	10.05	12.5	.192	49.79	.095	SI
	415.	20.	3.	1.	368473.	-12.3	532.	10.05	12.5	.156	49.79	.078	SI
	434.	39.	3.	1.	283689.	-9.5	409.6	10.05	12.5	.12	49.79	.06	SI
	479.	84.	3.	1.	121086.	-4.	174.8	10.05	12.5	.051	49.79	.025	SI
	525.	130.	3.	1.	-2804.	-.1	4.2	9.42	12.5	.001	29.38	0.	SI
	570.	175.	3.	1.	-88691.	-1.7	132.9	9.42	12.5	.039	29.38	.011	SI
	615.	220.	3.	1.	-137422.	-2.7	205.9	9.42	12.5	.06	29.38	.018	SI
	660.	265.	3.	1.	-149882.	-2.9	224.6	9.42	12.5	.066	29.38	.019	SI
	706.	311.	3.	1.	-126897.	-2.5	190.1	9.42	12.5	.056	29.38	.016	SI
	751.	356.	3.	1.	-69137.	-1.3	103.6	9.42	12.5	.03	29.38	.009	SI
	770.	375.	3.	1.	-31477.	-.6	47.2	9.42	12.5	.014	29.38	.004	SI
	790.	395.	3.	1.	6184.	-.2	8.9	10.05	12.5	.003	49.79	.001	SI
>	790.	0.	3.	1.	150.	0.	.2	10.05	12.5	0.	49.79	0.	SI
	810.	20.	3.	1.	-36440.	-.7	54.6	9.42	12.5	.016	29.38	.005	SI
	829.	39.	3.	1.	-73030.	-1.4	109.4	9.42	12.5	.032	29.38	.009	SI
	874.	84.	3.	1.	-128032.	-2.5	191.8	9.42	12.5	.056	29.38	.016	SI
	920.	130.	3.	1.	-147659.	-2.9	221.2	9.42	12.5	.065	29.38	.019	SI
	965.	175.	3.	1.	-130925.	-2.5	196.2	9.42	12.5	.057	29.38	.017	SI
	1010.	220.	3.	1.	-76691.	-1.5	114.9	9.42	12.5	.034	29.38	.01	SI
	1055.	265.	3.	1.	16223.	-.5	23.4	10.05	12.5	.007	49.79	.003	SI
	1101.	311.	3.	1.	148928.	-.5	215.	10.05	12.5	.063	49.79	.031	SI
	1146.	356.	3.	1.	322355.	-10.7	465.5	10.05	12.5	.136	49.79	.068	SI
	1165.	375.	3.	1.	412618.	-13.8	595.8	10.05	12.5	.174	49.79	.087	SI
	1185.	395.	3.	1.	502882.	-16.8	726.1	10.05	12.5	.213	49.79	.106	SI
>	1185.	0.	3.	1.	499935.	-16.7	721.9	10.05	12.5	.211	49.79	.105	SI
	1205.	20.	3.	1.	410070.	-13.7	592.1	10.05	12.5	.173	49.79	.086	SI
	1224.	39.	3.	1.	320205.	-10.7	462.4	10.05	12.5	.135	49.79	.067	SI
	1269.	84.	3.	1.	147736.	-4.9	213.3	10.05	12.5	.062	49.79	.031	SI
	1315.	130.	3.	1.	16067.	-.5	23.2	10.05	12.5	.007	49.79	.003	SI
	1360.	175.	3.	1.	-75689.	-1.5	113.4	9.42	12.5	.033	29.38	.01	SI
	1405.	220.	3.	1.	-128598.	-2.5	192.7	9.42	12.5	.056	29.38	.017	SI
	1450.	265.	3.	1.	-143797.	-2.8	215.4	9.42	12.5	.063	29.38	.019	SI
	1496.	311.	3.	1.	-122388.	-2.4	183.4	9.42	12.5	.054	29.38	.016	SI
	1541.	356.	3.	1.	-65330.	-1.3	97.9	9.42	12.5	.029	29.38	.008	SI
	1560.	375.	3.	1.	-27742.	-.5	41.6	9.42	12.5	.012	29.38	.004	SI
	1580.	395.	3.	1.	9845.	-.3	14.2	10.05	12.5	.004	49.79	.002	SI
>	1580.	0.	3.	1.	10098.	-.3	14.6	10.05	12.5	.004	49.79	.002	SI
	1600.	20.	3.	1.	-28084.	-.5	42.1	9.42	12.5	.012	29.38	.004	SI
	1619.	39.	3.	1.	-66265.	-1.3	99.3	9.42	12.5	.029	29.38	.009	SI
	1664.	84.	3.	1.	-124980.	-2.4	187.3	9.42	12.5	.055	29.38	.016	SI
	1710.	130.	3.	1.	-148635.	-2.9	222.7	9.42	12.5	.065	29.38	.019	SI
	1755.	175.	3.	1.	-136573.	-2.7	204.6	9.42	12.5	.06	29.38	.018	SI
	1800.	220.	3.	1.	-87984.	-1.7	131.8	9.42	12.5	.039	29.38	.011	SI
	1845.	265.	3.	1.	-2001.	0.	3.	9.42	12.5	.001	29.38	0.	SI
	1891.	311.	3.	1.	122200.	-4.1	176.4	10.05	12.5	.052	49.79	.026	SI
	1936.	356.	3.	1.	285306.	-9.5	412.	10.05	12.5	.121	49.79	.06	SI
	1955.	375.	3.	1.	370370.	-12.3	534.8	10.05	12.5	.157	49.79	.078	SI
	1975.	395.	3.	1.	455435.	-15.2	657.6	10.05	12.5	.192	49.79	.096	SI
>	1975.	0.	3.	1.	455276.	-15.2	657.4	10.05	12.5	.192	49.79	.096	SI
	1995.	20.	3.	1.	370676.	-12.4	535.2	10.05	12.5	.157	49.79	.078	SI
	2014.	39.	3.	1.	286077.	-9.5	413.1	10.05	12.5	.121	49.79	.06	SI
	2059.	84.	3.	1.	123891.	-4.1	178.9	10.05	12.5	.052	49.79	.026	SI
	2105.	130.	3.	1.	288.	0.	.4	10.05	12.5	0.	49.79	0.	SI
	2150.	175.	3.	1.	-85589.	-1.7	128.2	9.42	12.5	.038	29.38	.011	SI
	2195.	220.	3.	1.	-134738.	-2.6	201.9	9.42	12.5	.059	29.38	.017	SI
	2240.	265.	3.	1.	-148201.	-2.9	222.	9.42	12.5	.065	29.38	.019	SI
	2286.	311.	3.	1.	-126963.	-2.5	190.2	9.42	12.5	.056	29.38	.016	SI
	2331.	356.	3.	1.	-71848.	-1.4	107.6	9.42	12.5	.032	29.38	.009	SI
	2350.	375.	3.	1.	-35713.	-.7	53.5	9.42	12.5	.016	29.38	.005	SI
	2370.	395.	3.	1.	423.	0.	.6	10.05	12.5	0.	49.79	0.	SI

6- PORTALE METALLICO

Si verifica il portale metallico dell'atrio di ingresso sotto l'azione del vento e del sisma, nonché i carichi verticali spettanti. Da un punto di vista sismico esso è stato considerato di tipo pendolare assegnando tutta l'azione orizzontale al pilastro in c.a.

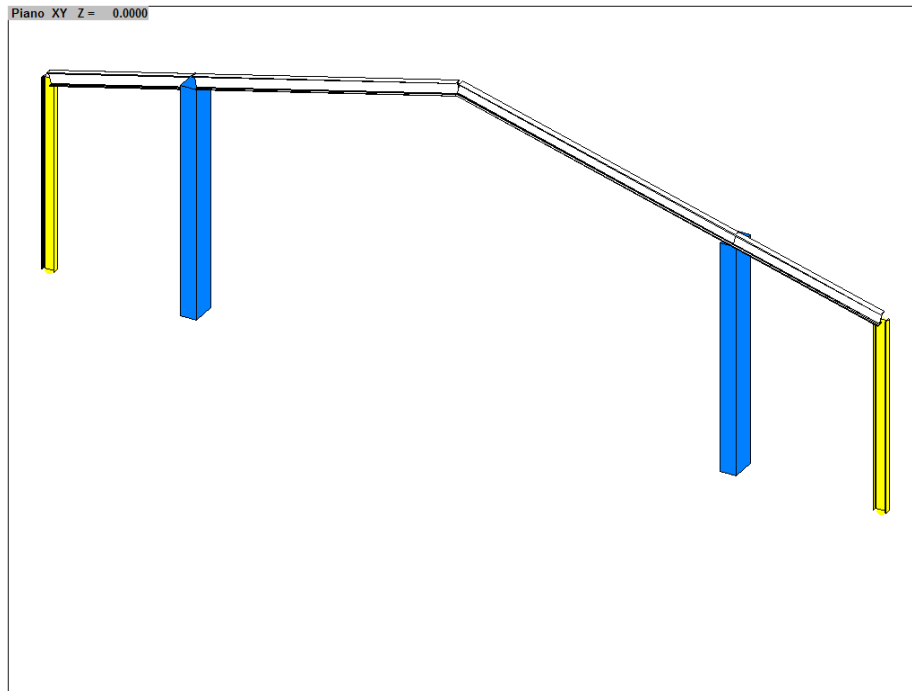

VERIFICA ELEMENTI IN ACCIAIO
 lavoro : MATCAP

Unita` di misura : Kgf ; cm ; Kgf/cmq ; Kgf*cm

MATERIALI

Fe360: Mod.El.= 2100000.; fd = 2350.(2100. per sp>40 mm)

CASI DI CARICO

N	Descrizione	Soll.
1	Caso 1	1
2	Cv+Sx	4
3	Cv+SY	4

CARATTERISTICHE GEOMETRICHE

P_IPE200_S001 (1) :

A = 28.5582E+00 Jz= 1.9488E+03 Jy=142.4164E+00 Jt= 4.9458E+00

P_IPE200_S001 (1) - metodo: stato limite ultimo - ASTA 3
 ----- PROGR. 0.00

SOLLECITAZIONI :

Caso	MZ	MY	MT	N	TZ	TY
2- 2	0.0	0.0	0.0	221.6	0.0	0.0

TENSIONI :

Caso	Ve	No	massimi	Sx	Tz	Ty	Si
2- 2	si	1	Sx Si	7.8	0.0	0.0	7.8
2- 2	si	5	Tz	7.8	0.0	0.0	7.8
2- 2	si	9	Ty	7.8	0.0	0.0	7.8

----- PROGR. 150.00

SOLLECITAZIONI :

Caso	MZ	MY	MT	N	TZ	TY
2- 2	0.0	0.0	0.0	255.2	0.0	0.0

TENSIONI :

Caso	Ve	No	massimi	Sx	Tz	Ty	Si
2- 2	si	1	Sx Si	8.9	0.0	0.0	8.9
2- 2	si	5	Tz	8.9	0.0	0.0	8.9
2- 2	si	9	Ty	8.9	0.0	0.0	8.9

----- PROGR. 300.00

SOLLECITAZIONI :

Caso	MZ	MY	MT	N	TZ	TY
2- 2	0.0	0.0	0.0	288.7	0.0	0.0

TENSIONI :

Caso	Ve	No	massimi	Sx	Tz	Ty	Si
2- 2	si	1	Sx Si	10.1	0.0	0.0	10.1
2- 2	si	5	Tz	10.1	0.0	0.0	10.1
2- 2	si	9	Ty	10.1	0.0	0.0	10.1

Asta Tesa Per tutte le condizioni di carico.

P_IPE200_S001 (1) - metodo: stato limite ultimo - ASTA 4
 ----- PROGR. 0.00

SOLLECITAZIONI :

Caso	MZ	MY	MT	N	TZ	TY
2- 1	0.0	0.0	0.0	228.9	0.0	0.0

TENSIONI :

Caso	Ve	No	massimi	Sx	Tz	Ty	Si
2- 1	si	1	Sx Si	8.0	0.0	0.0	8.0
2- 1	si	5	Tz	8.0	0.0	0.0	8.0
2- 1	si	9	Ty	8.0	0.0	0.0	8.0

----- PROGR. 150.00

SOLLECITAZIONI :

Caso	MZ	MY	MT	N	TZ	TY
2- 1	0.0	0.0	0.0	262.5	0.0	0.0

TENSIONI :

Caso	Ve	No	massimi	Sx	Tz	Ty	Si
2- 1	si	3	Sx Si	9.2	0.0	0.0	9.2
2- 1	si	5	Tz	9.2	0.0	0.0	9.2
2- 1	si	9	Ty	9.2	0.0	0.0	9.2

----- PROGR. 300.00

SOLLECITAZIONI :

Caso	MZ	MY	MT	N	TZ	TY
2- 1	0.0	0.0	0.0	296.0	0.0	0.0

TENSIONI :

Caso	Ve	No	massimi	Sx	Tz	Ty	Si
2- 1	si	3	Sx Si	10.4	0.0	0.0	10.4
2- 1	si	5	Tz	10.4	0.0	0.0	10.4

| 2- 1|si| 9| Ty | 10.4| 0.0| 0.0| 10.4|
 Asta Tesa Per tutte le condizioni di carico.
 P_IPE200_S001 (1) - metodo: stato limite ultimo - ASTA 7
 ----- PROGR. 0.00

SOLLECITAZIONI :

Caso	MZ	MY	MT	N	TZ	TY
2- 2	0.0	0.0	0.0	316.1	0.0	-215.3
2- 1	0.0	0.0	0.0	-201.9	0.0	-217.9

TENSIONI :

Caso	Ve	No	massimi	Sx	Tz	Ty	Si
2- 2	si	4	Sx	11.1	0.0	0.0	11.1
2- 1	si	6	Tz	-7.1	3.8	0.0	9.6
2- 1	si	9	Ty	-7.1	0.0	22.1	38.9
2- 2	si	9	Si	11.1	0.0	21.8	39.4

----- PROGR. 118.93

SOLLECITAZIONI :

Caso	MZ	MY	MT	N	TZ	TY
2- 2	-51068.1	0.0	0.0	428.9	0.0	-643.5
2- 1	-51381.9	0.0	0.0	-89.0	0.0	-646.2

TENSIONI :

Caso	Ve	No	massimi	Sx	Tz	Ty	Si
2- 2	si	1	Sx	277.1	0.0	0.0	277.1
2- 1	si	5	Tz	260.5	-11.2	0.0	261.3
2- 1	si	9	Ty	-3.1	0.0	65.5	113.5
2- 2	si	5	Si	277.1	-11.1	0.0	277.7

----- PROGR. 237.85

SOLLECITAZIONI :

Caso	MZ	MY	MT	N	TZ	TY
2- 2	-153064.3	0.0	0.0	541.8	0.0	-1071.7
2- 1	-153691.7	0.0	0.0	23.9	0.0	-1074.4

TENSIONI :

Caso	Ve	No	massimi	Sx	Tz	Ty	Si
2- 2	si	1	Sx	804.4	0.0	0.0	804.4
2- 1	si	5	Tz	789.5	-18.6	0.0	790.1
2- 1	si	9	Ty	0.8	0.0	108.9	188.7
2- 2	si	5	Si	804.4	-18.5	0.0	805.0

 VERIFICA STABILITA` :

Caso 2- 1 |L0 = 237.9|Lc = 237.9|Ro = 2.2 |lm= 106.5|
 Nodo 3 |om = 1.96|csz= 1.00|csy= 1.01|
 Infless. Y
 |Ncrz = 713941.7|Ncry= 52174.2|
 |Nmax = -201.9|Mzeq= -115268.8|Myeq= 0.0|
 Ss = -605.6

P_IPE200_S001 (1) - metodo: stato limite ultimo - ASTA 8
 ----- PROGR. 0.00

SOLLECITAZIONI :

Caso	MZ	MY	MT	N	TZ	TY
2- 2	-153064.3	0.0	0.0	-2001.3	0.0	1329.9
2- 1	-153691.7	0.0	0.0	-703.2	0.0	1332.5

TENSIONI :

Caso	Ve	No	massimi	Sx	Tz	Ty	Si
2- 2	si	3	Sx	-855.5	0.0	0.0	855.5
2- 1	si	5	Tz	764.0	23.0	0.0	765.1
2- 1	si	9	Ty	-24.6	0.0	-135.1	235.3
2- 2	si	7	Si	-855.5	-23.0	0.0	856.4

----- PROGR. 214.59

SOLLECITAZIONI :

Caso	MZ	MY	MT	N	TZ	TY
2- 2	49404.5	0.0	0.0	-1797.6	0.0	557.2
2- 1	49336.3	0.0	0.0	-499.6	0.0	559.8

TENSIONI :

Caso	Ve	No	massimi	Sx	Tz	Ty	Si
2- 2	si	2	Sx	-316.5	0.0	0.0	316.5
2- 1	si	6	Tz	-270.7	-9.7	0.0	271.2
2- 1	si	9	Ty	-17.5	0.0	-56.8	99.8
2- 2	si	6	Si	-316.5	-9.6	0.0	316.9

----- PROGR. 429.17

SOLLECITAZIONI :

Caso	MZ	MY	MT	N	TZ	TY
2- 2	86068.4	0.0	0.0	-1594.0	0.0	-215.5

TENSIONI :

Caso	Ve	No	massimi	Sx	Tz	Ty	Si
2- 2	si	2	Sx	-497.5	0.0	0.0	497.5
2- 2	si	5	Tz	-497.5	-3.7	0.0	497.5
2- 2	si	9	Ty	-55.8	0.0	21.8	67.4
2- 2	si	6	Si	-497.5	3.7	0.0	497.5

 VERIFICA STABILITA` :

Caso 2- 2 |L0 = 429.2|Lc = 429.2|Ro = 2.2 |lm= 192.2|
 Nodo 3 |om = 5.13|csz= 1.01|csy= 1.23|
 Infless. Y
 |Ncrz = 219291.7|Ncry= 16025.6|
 |Nmax = -2001.3|Mzeq= -114798.3|Myeq= 0.0|
 Ss = -956.6

P_IPE200_S001 (1) - metodo: stato limite ultimo - ASTA 9
 ----- PROGR. 0.00

SOLLECITAZIONI :

Caso	MZ	MY	MT	N	TZ	TY
2- 1	86559.4	0.0	0.0	-1590.0	0.0	271.8
2- 2	86068.4	0.0	0.0	-269.6	0.0	273.2

TENSIONI :

Caso	Ve	No	massimi	Sx	Tz	Ty	Si
2- 1	si	2	Sx	-499.8	0.0	0.0	499.8
2- 2	si	6	Tz	-451.1	-4.7	0.0	451.2
2- 2	si	9	Ty	-9.4	0.0	-27.7	48.9
2- 1	si	6	Si	-499.8	-4.7	0.0	499.9

----- PROGR. 224.49

SOLLECITAZIONI :

Caso	MZ	MY	MT	N	TZ	TY
2- 1	56678.0	0.0	0.0	-1797.1	0.0	-538.1

TENSIONI :

Caso	Ve	No	massimi	Sx	Tz	Ty	Si
2- 1	si	2	Sx	-353.8	0.0	0.0	353.8
2- 1	si	5	Tz	-353.8	-9.3	0.0	354.1
2- 1	si	9	Ty	-62.9	0.0	54.6	113.5
2- 1	si	6	Si	-353.8	9.3	0.0	354.1

----- PROGR. 448.99

SOLLECITAZIONI :

Caso	MZ	MY	MT	N	TZ	TY
2- 1	-155023.7	0.0	0.0	-2004.1	0.0	-1348.0

TENSIONI :

Caso	Ve	No	massimi	Sx	Tz	Ty	Si
2- 1	si	3	Sx	-865.7	0.0	0.0	865.7
2- 1	si	5	Tz	725.3	-23.3	0.0	726.4
2- 1	si	9	Ty	-70.2	0.0	136.7	246.9
2- 1	si	8	Si	-865.7	-23.3	0.0	866.6

 VERIFICA STABILITA` :

Caso 2- 1 |L0 = 449.0|Lc = 449.0|Ro = 2.2 |lm= 201.1|
 Nodo 3 |om = 5.56|csz= 1.02|csy= 1.26|
 Infless. Y
 |Ncrz = 200361.6|Ncry= 14642.2|
 |Nmax = -2004.1|Mzeq= -116267.8|Myeq= 0.0|
 Ss = -996.0

P_IPE200_S001 (1) - metodo: stato limite ultimo - ASTA 10
 ----- PROGR. 0.00

SOLLECITAZIONI :

Caso	MZ	MY	MT	N	TZ	TY
2- 1	-155023.7	0.0	0.0	534.8	0.0	1081.2

TENSIONI :

Caso	Ve	No	massimi	Sx	Tz	Ty	Si
2- 1	si	1	Sx	814.2	0.0	0.0	814.2
2- 1	si	5	Tz	814.2	18.7	0.0	814.9
2- 1	si	9	Ty	18.7	0.0	-109.6	190.8

----- PROGR. 118.70

SOLLECITAZIONI :

Caso	MZ	MY	MT	N	TZ	TY
2- 1	-52096.9	0.0	0.0	425.3	0.0	653.0

TENSIONI :

Caso	Ve	No	massimi	Sx	Tz	Ty	Si
------	----	----	---------	----	----	----	----

2- 1	si	1	Sx		282.2	0.0	0.0	282.2
2- 1	si	5	Tz	Si	282.2	11.3	0.0	282.9
2- 1	si	9	Ty		14.9	0.0	-66.2	115.6
								----- PROGR. 237.40

SOLLECITAZIONI :

Caso	MZ		MY		MT		N		TZ		TY
2- 1		0.0	0.0		0.0		315.8		0.0		224.8

TENSIONI :

Caso	Ve	No	massimi		Sx		Tz		Ty		Si
2- 1	si	4	Sx		11.1		0.0		0.0		11.1
2- 1	si	5	Tz		11.1		3.9		0.0		12.9
2- 1	si	9	TySi		11.1		0.0		-22.8		41.0

VERIFICA STABILITA` :

Caso 2- 2	L0 = 237.4	Lc = 237.4	Ro = 2.2	lm= 106.3
Nodo 3	om = 1.96	csz= 1.00	csy= 1.01	
Infless. Y	Ncrz = 716699.7	Ncry= 52375.8		
	Nmax = -201.0	Mzeq= -116192.8	Myeq= 0.0	
	Ss = -610.2			